

Technical  
Information

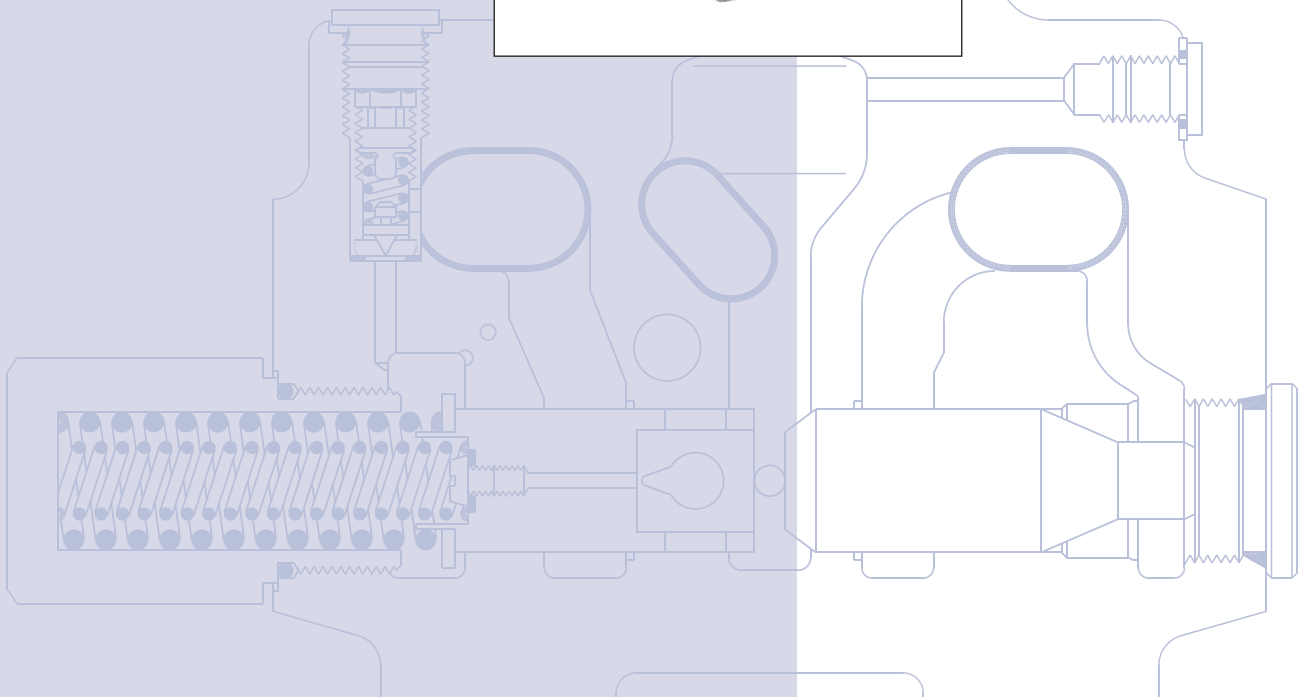

Table of Revisions

Date	Page	Changed	Rev
Apr 2010	Various	Layout, drawings and others	HA
Sep 2010	29, 44	Drawing, new back cover	HB
Sep 2011	All	TOC moved all pages by one, Safety section, SD layout.	IA
May 2012	22-23	Tables PVHC, PVE.	IB
Jul 2012	42	PVM table data	IC

## Contents

<b>General Information</b>	Valve system.....	4
	General characteristics .....	4
	Pump side module – PVP .....	4
	Basic module – PVB .....	4
	Actuation modules .....	4
	Remote controls units.....	5
	Electronic accessories .....	5
<b>Function</b>	PVG 120 with Open Centre PVP .....	6
	PVG 120 with Closed Centre PVP .....	6
	PVG 120 Sectional Drawing.....	7
<b>Hydraulic Systems</b>	Examples .....	8
<b>Technical Data</b>	PVG 120 Valve Group .....	10
	Mechanical Actuation PVM.....	10
	Hydraulic Actuation PVH .....	10
	PVE, Electrical Actuation .....	11
	PVEO.....	11
	PVEH.....	11
	PVPE, Electrical Relief Valve, Normally Open .....	12
<b>Electrical Actuation</b>	PVEO, ON-OFF.....	13
	PVEH, Proportional High.....	13
	PVEH, LVDT-Transducer .....	14
	PVEH, Pulse Width Modulation.....	14
	PVEH, Fault Monitoring .....	14
	Fault Monitoring Specification .....	15
	PVEH, Connection to Fault Monitoring Output.....	16

© 2012 Sauer-Danfoss. All rights reserved.

Sauer-Danfoss accepts no responsibility for possible errors in catalogs, brochures and other printed material. Sauer-Danfoss reserves the right to alter its products without prior notice. This also applies to products already ordered provided that such alterations can be made without affecting agreed specifications. All trademarks in this material are properties of their respective owners. Sauer-Danfoss, the Sauer-Danfoss logotype, the Sauer-Danfoss S-icon, PLUS+1™, What really matters is inside® and Know-How in Motion™ are trademarks of the Sauer-Danfoss Group.

Frontpage: F301 112, F300 001, F300 009, F300 011, Drawing 155B569.eps

<b>Modules and Code Numbers</b>	PVP and PVPV, Pump Side Modules .....	17
	PVP, Accessories for Open Centre Pump Side Modules .....	18
	PVB, Basic Modules .....	19
	PVB, Accessories for Basic Modules .....	20
	PVLP, Shock and Suction Valves for A and B Port Connections.....	21
	PVLA, Suction Valve .....	21
	PVBS, Main Spools.....	22
	PVM, Mechanical Actuation.....	22
	PVMD, Cover for Mechanical Actuation .....	22
	PVH, Hydraulic Actuation .....	23
	PVH, High Current Actuator.....	23
	PVE, Electrical Actuation .....	23
	PVT, Tank Side Modul.....	24
	PVAS, Assembly Kit .....	24
	Modules for Oil Flow Exceeding 180 l/min [47.6 US gal/min].....	25
	Pump with fixed displacement.....	25
Pump with variable displacement.....	25	
<b>Technical Characteristics</b>	General.....	26
	PVP, Pump Side Module .....	26
	PVB, Basic Module .....	27
	PVLP, Shock Valve (Pressure Relief Valve in PVLP).....	29
	PVLP/PVLA, Suction Function .....	29
<b>Dimensions</b>	Valve Dimensions .....	30
	General Dimensions .....	31
<b>Lever Positions</b>	PVM, Lever Positions .....	32
<b>Safety in Application</b>	Building in Safety .....	33
	FMEA (Failure Mode and Effect Analysis) IEC EN 61508.....	33
	Hazard and Risk Analysis ISO 12100-1 / 14121.....	33
	Control System Example.....	34
	PVG32 – Mainly used in system with fixed displacement pumps.....	36
	PVG100 – Alternative LS dump or pilot supply disconnect.....	36
PVG120 – Pump disconnect/block for variable pumps .....	36	
<b>Other Operating Conditions</b>	Oil, Particle Content, Degree of Contamination.....	38
	Mineral oil, Non-flammable fluids, Biodegradable oils .....	38
	Filtering .....	39
	Conversion Factors .....	39
<b>Order Specification</b>	Order Form .....	40
	Reordering.....	41
<b>Module Selection Chart</b>	Module Selection Chart .....	42

## General

### Valve system

Load sensing proportional valve type PVG 120 is a combined directional and flow control valve which is supplied as a valve group consisting of modules specified to match particular customer needs. The flexible nature of this valve will allow an existing valve bank to be easily adapted to suit changes in requirements.

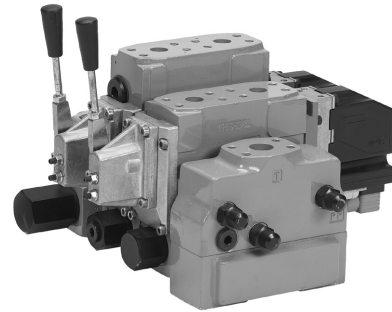

F300 011

### General characteristics

- Load-independent flow control:
  - Oil flow to an individual function is independent of the load of this function
  - Oil flow to one function is independent of the load pressure of other functions
- Good regulation characteristics
- Central pilot supply built in when the valves are actuated electrohydraulically
- Energy-saving
- Up to eight basic modules per valve group

### Pump side module – PVP

- Built-in pressure relief valve
- System pressure up to 400 bar [5800 psi]
- Pressure gauge connection
- Versions:
  - Open centre version for systems with fixed displacement pumps
  - Open centre version prepared for an extra relief module
  - Closed centre version for systems with variable displacement pumps
  - Closed centre version without system pressure relief valve for variable displacement pumps with built-in pressure relief valve.

### Basic module – PVB

- Integrated pressure compensator in channel P
- Interchangeable spools
- Depending on requirements the basic module can be supplied with:
  - Shock/suction valves
  - Adjustable LS pressure limiting valve for ports A and B
  - LS connection
  - Module for oil flows exceeding 180 l/min [47.6 gpm]
  - Different spool variants

### Actuation modules

The basic module is always fitted with mechanical actuation PVM, which can be combined with the following as required:

- Electrical actuation
  - PVEH- proportional, high performance (11 - 32 V $\Rightarrow$ )
  - PVEO - On/off (12 V $\Rightarrow$  or 24 V $\Rightarrow$ )
- Cover for hydraulic remote control, PVH
- Cover for mechanically actuated valve group, PVMD

**General**

**Remote controls units**

- PVRE, electrical control unit, 162F...

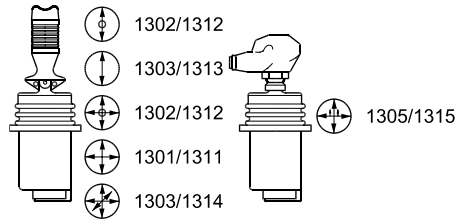

155B566.10

- Prof 1, 162F...

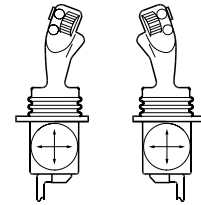

162B73.10

- PVREL, electrical control unit, 155U...

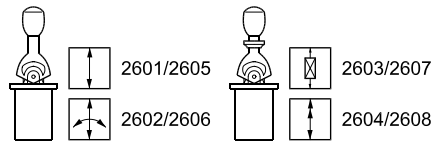

155B486.10

- PVRES, electrical control unit, 155B...

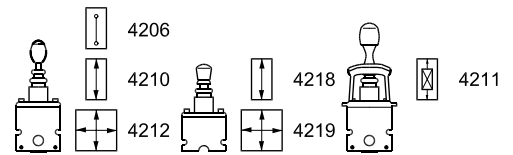

155B485.10

- PVRH, hydraulic control unit, 155N...

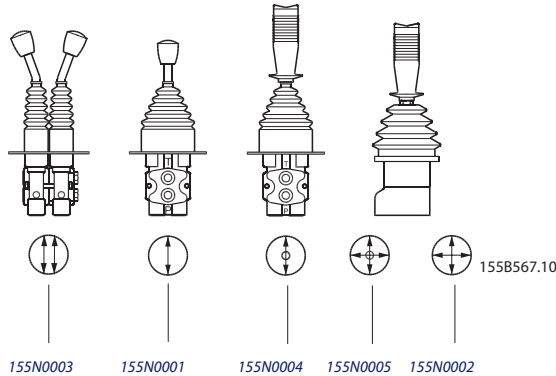

155N0003

155N0001

155N0004

155N0005

155N0002

155B567.10

**Electronic accessories**

- EHF, low adjustment unit
- EHR, ramp generator
- EHS, speed control
- EHSC, closed loop speed control
- EHA, alarm logic
- EHC, closed loop position control

## PVG 120 Proportional Valve

### Technical Information

#### Function

#### PVG 120 with Open Centre PVP

When the pump is started and the main spools (1) in the individual basic modules are in neutral position, oil flows from the pump, through connection P, across the pressure adjustment spool (2) to tank.

The oil flow led across the pressure adjustment spool determines the pump pressure (stand-by pressure). If a reduced stand-by pressure is required, an extra relief valve PVPH or PVPE can be used in PVP (*see characteristics for neutral flow pressure, page 25*).

When the main spools are actuated the highest load pressure is distributed across the shuttle valve circuit (3) to the spring chamber behind the pressure adjustment spool (2) and completely or partly closes the connection to tank.

The pump pressure is applied to the right-hand side of the pressure adjustment spool (2). The pressure relief valve (4) opens when the load pressure exceeds the set value, allowing pump flow to be diverted back to tank.

In the basic module the compensator (5) maintains a constant pressure drop across the main spool – both when the load changes and when a module with a higher load pressure is activated.

Shock and suction valves with a fixed setting (7) and the suction valves (8) on ports A and B are used to protect individual working functions against overload.

In the basic module it is possible to build in an adjustable LS pressure relief valve (6) to limit the pressure from each working function.

The LS pressure limiting valve saves energy:

- Without LS pressure limiting valve all the oil flow to the working function will be led across the combined shock and suction valves to tank if the pressure exceeds the fixed setting of the valves.
- With LS pressure limiting valve an oil flow of only about 2 l/min [0.5 US gal/min] will be led across the LS pressure limiting valve to tank if the pressure exceeds the valve setting.

#### PVG 120 with Closed Centre PVP

In the closed centre version an orifice (9) has been fitted instead of the plug. This means that the pressure adjustment spool (2) will only open to tank when the pressure in channel P exceeds the pressure relief valve setting (4).

In load sensing systems the load pressure is led to the pump regulator via the LS connection (10). So the orifices (11) have been removed, and a plug (12) has been fitted instead of one of the orifices.

In neutral position the pump regulator will set the displacement so that leakage in the system is just compensated for.

When a main spool is activated, the pump regulator will adjust the displacement so that the set differential pressure between P and LS is maintained.

The pressure relief valve (4) in PVP is set for a pressure of about 30 bar [435 psi] above maximum system pressure (set at the pump or an external pressure relief valve). If the system or the pump regulation has a pressure relief valve, it is possible to use a PVPV pump side module, without integrated pressure adjustment spool and pressure relief valve.



**Examples**

*PVG 120 with fixed displacement pump*

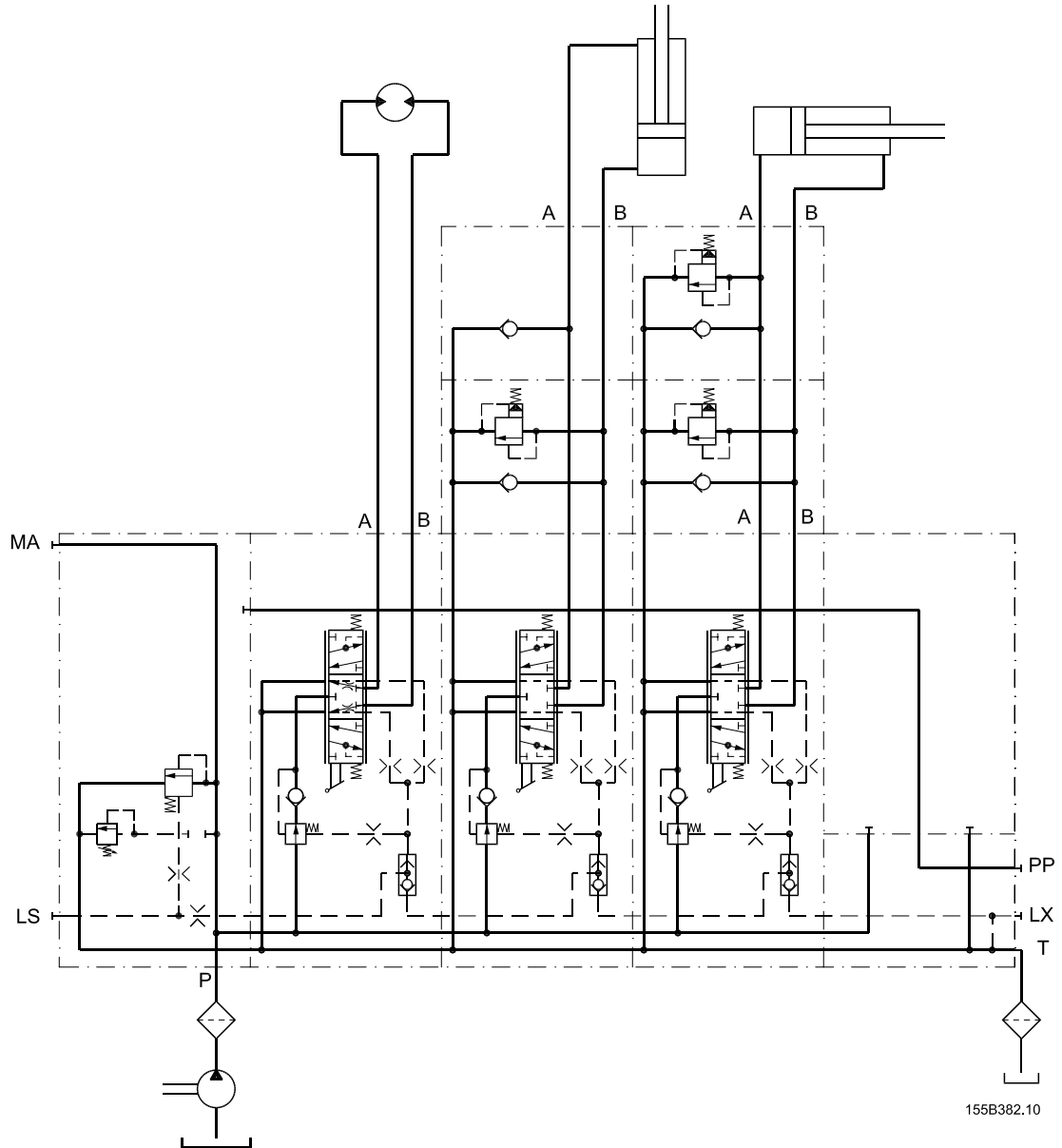



**Examples**

*PVG 120 with variable displacement pump*

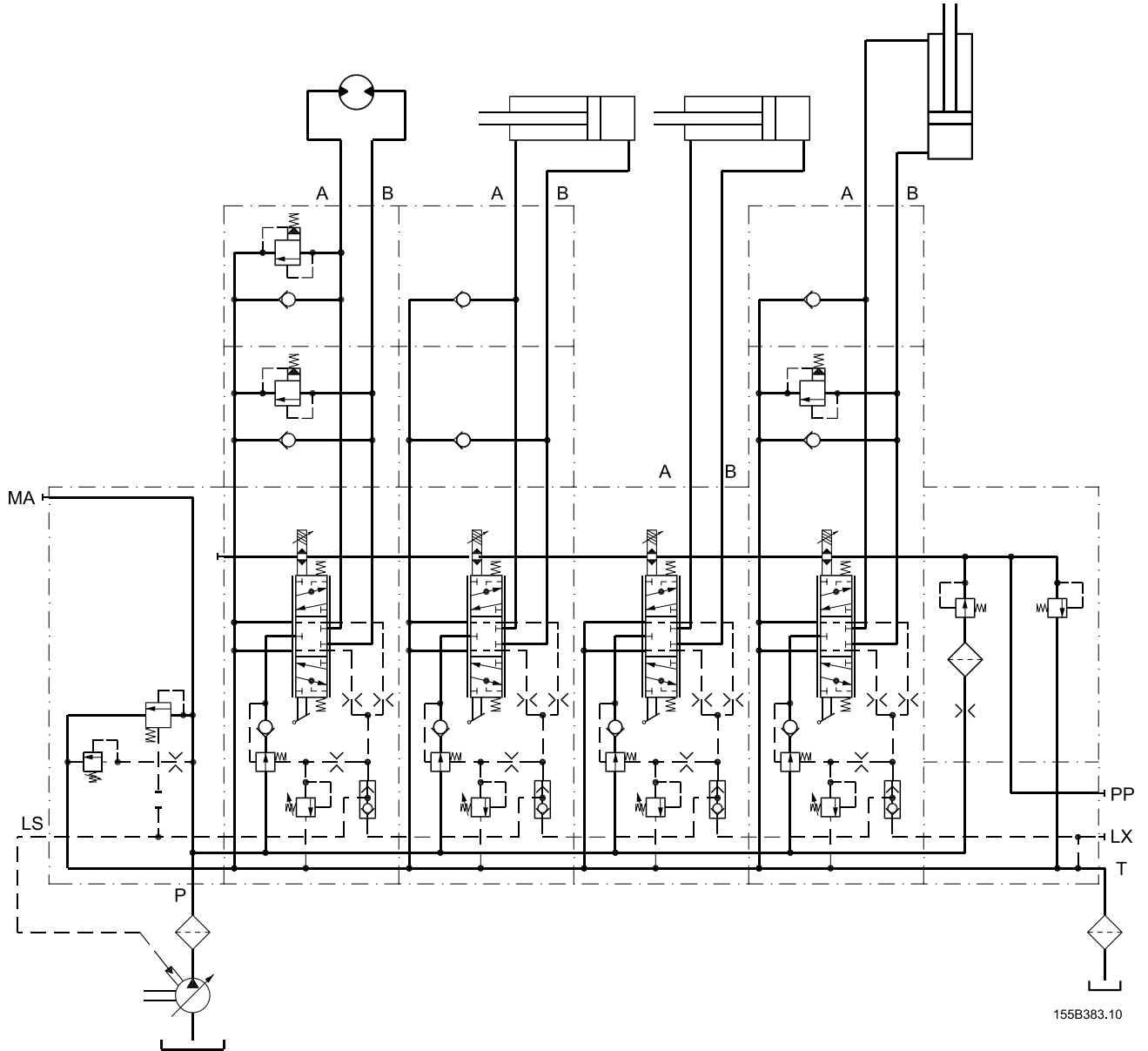

PVG 120 Valve Group

<b>Max. pressure</b>	<b>Port P</b>	<b>continuous</b>	350 bar	[5075 psi]
		<b>intermittent<sup>1)</sup></b>	400 bar	[5800 psi]
	<b>Port A/B</b>		400 bar	[5800 psi]
	<b>Port T, static/dynamic</b>		25 bar/40 bar	[365/580 psi]
<b>Oil flow, (see characteristics page 27)</b>	<b>Port P, rated max.</b>		240/300 l/min	[63.4/79.3 gpm]
	<b>Port A/B</b>		65/95/130/180/210/240 l/min <sup>2)</sup>	[17.2/25.1/34.3/47.6/55.5/63.4 gpm <sup>2)</sup>
<b>Spool travel</b>			± 8 mm	[± 0.32 in]
<b>Dead band (± 25%)</b>			± 2 mm	[± 0.08 in]
<b>Max. internal leakage at 100 bar, 21 mm<sup>2</sup>/s</b>	<b>A/B → T, without shockvalve</b>		90 cm <sup>3</sup> /min	[5.5 in <sup>3</sup> /min]
	<b>A/B → T, with shockvalve</b>		95 cm <sup>3</sup> /min	[5.6 in <sup>3</sup> /min]
<b>Oil temperature (inlet temperature)</b>	<b>Recommended temperature</b>		30 to 60°C	[86 to 140°F]
	<b>Min. temperature</b>		-30°C	[-22°F]
	<b>Max. temperature</b>		+90°C	[+194°F]
<b>Ambient temperature</b>			-30 to +60°C	[-22 to +140°F]
<b>Oil viscosity</b>	<b>Operating range</b>		12 to 75 mm <sup>2</sup> /s	[65 SUS to 347 SUS]
	<b>Min. viscosity</b>		4 mm <sup>2</sup> /s	[39 SUS]
	<b>Max. viscosity</b>		460 mm <sup>2</sup> /s	[2128 SUS]
<b>Filtering (See page 39)</b>	<b>Max. contamination (ISO 4406)</b>		23/19/16	
<b>Oil consumption in pressure reduction valve for PVT at PVE pilot-oil supply</b>			0.4 l/min	[0.1 gpm]

1) Intermittent operation: the permissible values may occur for max. 10% of every minute.

2) See page 25 regarding the ordering or conversion of valve groups for oil flows exceeding 180 l/min [47.6 gpm].

**Mechanical Actuation PVM**

<b>Operating force</b>	<b>PVM + PVMD</b>	Neutral position	2.8 ± 0.2 N·m	4.0 ± 0.2 N·m
			[24.8 ± 1.8 lbf·in]	[35.5 ± 1.8 lbf·in]
	<b>PVM + PVE (without voltage)</b>	2.8 ± 0.2 N·m	4.0 ± 0.2 N·m	
		[24.8 ± 1.8 lbf·in]	[35.5 ± 1.8 lbf·in]	
	<b>PVM + PVH</b>	4.7 ± 0.2 N·m	12.8 ± 0.2 N·m	
		[41.6 ± 1.8 lbf·in]	[113.3 ± 1.8 lbf·in]	
<b>Possible control lever positions</b>	<b>Number</b>	2 × 5		
<b>Regulation range, control lever</b>		±19,5°		

**Hydraulic Actuation PVH**

<b>Control range</b>	5 to 15 bar	[75 to 220 psi]
<b>Max. pilot pressure, static</b>	35 bar	[510 psi]
<b>Max. pressure on port T *</b>	3 bar	[45 psi]

\* It is recommended that the tank connection from the hydraulic remote control unit PVRH is taken direct to tank.

**PVE, Electrical Actuation**

Actuation		PVEO ON/OFF	PVEH Proportional High
Hysteresis (applies to the electrical actuation only) <sup>1)</sup>	Typical	-	4%
Reaction time from neutral position to max. spool travel	Typical	250 ms	250 ms
	Max.	350 ms	280 ms
Reaction time from max. spool travel to neutral position <sup>2)</sup>	Typical	240 ms	150 ms
	Max.	330 ms	200 ms
Pilot oil flow pr. PVE	Neutral position without voltage	0 l/min / [US/gal min]	
	Locked with voltage <sup>3)</sup>	0 l/min / [US/gal min]	
Enclosure to IEC 529		IP65	

- 1) The hysteresis is stated at rated and  $f = 0,02$  Hz for a cycle. One cycle includes the movement from neutral position to max. spool travel direction A, via neutral position to max. spool travel in direction B, and back to neutral position. Further information can be obtained by contacting the Sales Organization for Sauer-Danfoss.
- 2) Reaction times for PVEH is reduced by 20 by 30 ms if the voltage is not interrupted during the neutral positioning (remote control lever without neutral position switch).
- 3) Total oil consumption for a spool movement from N to full A or B: 0.0035 l [0.0009 US gal]

**PVEO**

		PVEO	
Supply voltage UDC	rated	12 V DC	24 V DC
	range	11 V to 15 V	22 V to 30 V
	max. ripple	5%	
Current consumption at rated voltage		0.65 A @ 12 V	0.33 A @ 24 V
Signal voltage (PVEM)	neutral	0.5 x UDC	
	A-port ↔ B-port	0.25 · UDC to 0.75 · UDC	
Signal current at rated voltage (PVEM)		0.25 mA	0.50 mA
Input impedance in relation to 0.5 · UDC		12 KΩ	
Power consumption		8 W	

**PVEH**

		PVEH	
Supply voltage UDC	rated	11 V to 32 V	
	range	11 V to 32 V	
	max. ripple	5%	
Current consumption at rated voltage		0.57 (0.33) A @ 12 V	0.3 (0.17) A @ 24 V
Signal voltage	neutral	0.5 x UDC	
	A-port ↔ B-port	0.25 · UDC to 0.75 · UDC	
Signal current at rated voltage		0.25 mA to 0.70 mA	
Input impedance in relation to 0.5 · UDC		12 KΩ	
Input capacitor		100 F	
Power consumption		7 (3.5) W	
PVEH	Active	Max. load	100 mA
		Reaction time at fault	500 ms
	Passive	Reaction time at fault	250 ms

**PVPE, Electrical Relief Valve, Normally Open**

<b>Max. operation pressure</b>		350 bar [5085 psi]	
<b>Max. pressure drop a an flow of 0.20 l/min. [0.053 US gal/min]</b>		1.2 bar [17 psi]	
<b>Oil temperature (inlet temperature)</b>	<b>Recommended temperature</b>	30 to 60°C [86 to 140°F]	
	<b>Min. temperature</b>	-30°C [-22°F]	
	<b>Max. temperature</b>	+90°C [+194°F]	
<b>Max. coil surface temperature</b>		155°C [311°F]	
<b>Ambient temperature</b>		-30 to +60°C [-22 to +140°F]	
<b>Oil viscosity</b>	<b>Operating range</b>	12 to 75 mm <sup>2</sup> /s [65 to 347 SUS]	
	<b>Min. viscosity</b>	4 mm <sup>2</sup> /s [39 SUS]	
	<b>Max. viscosity</b>	460 mm <sup>2</sup> /s [2128 SUS]	
<b>Response time for pressure relief to tank</b>		600 ms	
<b>Enclosure to. IEC 529</b>		IP 65	
<b>Rated voltage</b>		12 V	24 V
<b>Max. permissible deviation from rated supply voltage</b>		± 10 %	± 10 %
<b>Current consumption at rated voltage</b>	<b>at 22°C [72°F] coil temperature</b>	1.55 A	0.78 A
	<b>at 85°C [230°F] coil temperature</b>	1.00 A	0.50 A
<b>Power consumption</b>	<b>at 22°C [72°F] coil temperature</b>	19 W	19 W
	<b>at 85°C [230°F] coil temperature</b>	12 W	12 W

**PVEO, ON-OFF**

Main features of PVEO:

- Compact
- Robust operation
- With Hirschmann or AMP connector
- Low electrical power

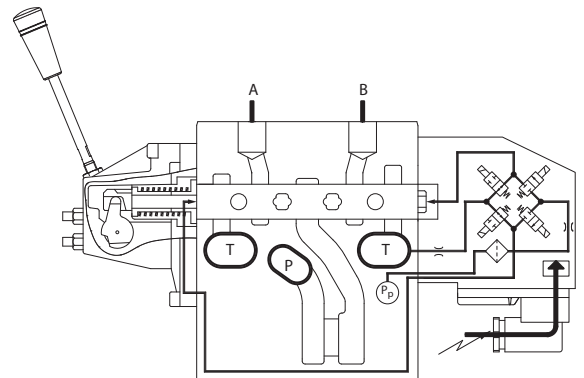

V310185.A

**PVEH, Proportional High**

PVEH adjusts the main spool position so that it corresponds to an electrical control signal – for example from a remote control unit.

The control signal (set-point signal) is converted into a hydraulic pressure which moves the main spool. The position of the main spool is converted in the positional transducer (C) to an electric signal (feed-back signal). This signal is registered by the electronics.

The variation between the set-point signal and feed-back signal actuates the solenoid valves. Thus the hydraulic pressure moves the main spool into the correct position.

Special features of PVEH:

- Inductive transducer
- Integrated pulse width modulation
- Low hysteresis
- Fast reaction time
- Hirschmann or AMP connector
- Fault monitoring with transistor output for signal source
- Low electrical power
- No set-up procedure

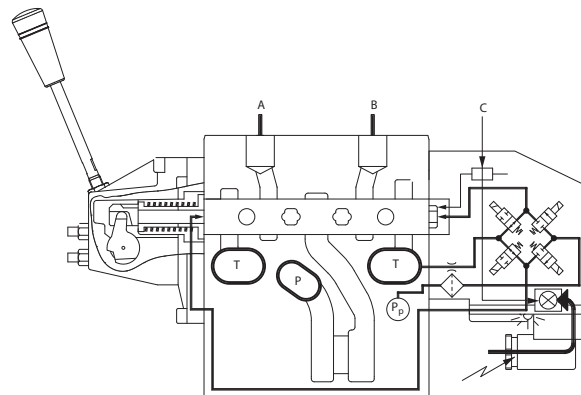

V310099.A

#### PVEH, LVDT-Transducer

##### **LVDT, Inductive transducer (Linear Variable Differential Transformer)**

When the main spool is moved a voltage is induced proportional to the spool position. The use of LVDT gives contact-free (proximity) registration of the main spool position. This means an extra-long working life and no limitation as regards the type of hydraulic fluid used. In addition, LVDT gives a precise position signal of high resolution.

#### PVEH, Pulse Width Modulation

##### **Integrated pulse width modulation**

Positioning of the main spool in PVEH is based on the pulse width modulation principle. As soon as the main spool reaches the required position, modulation stops and the spool is locked in position.

#### PVEH, Fault Monitoring

A fault monitoring system is provided in all PVEA, PVEH and PVES modules. The system is available in two versions:

- The active fault monitoring type, which provides a warning signal, deactivates the solenoid valves and drives the spool in neutral.
- The passive fault monitoring type, which provides a warning signal only.

Both active and passive fault monitoring systems are triggered by three main events:

##### *1. Input signal monitoring*

The input signal voltage is continuously monitored. The permissible range is between 15% and 85% of the supply voltage. Outside this range the section will switch into an active error state.

##### *2. Transducer supervision*

If one of the wires to the LVDT sensor is broken or short-circuited, the section will switch into an active error state.

##### *3. Supervision of the closed loop*

The actual position must always correspond to the demanded position (input signal). If the actual spool position is further than the demanded spool position (>12%, PVEA: >25%), the system detects an error and will switch into an active error state. On the other hand, a situation where the actual position is closer to neutral than that demanded will not cause an error state. This situation is considered "in control".

When an active error state occurs, the fault monitoring logic will be triggered:

##### **Active fault monitoring**

- A delay of 500 ms (PVEA: 750 ms) before anything happens.
- The solenoid valve bridge will be disabled and all solenoid valves will be released.
- An alarm signal is sent out through the appropriate pin connection.
- This state is memorized and continues until the system is actively reset (by turning off the supply voltage).

##### **Passive fault monitoring**

- A delay of 250 ms (PVEA: 750 ms) before anything happens.
- The solenoid valve bridge will not be disabled but still control the main spool position.
- An alarm signal is sent out through the appropriate pin connection.
- This state is not memorized. When the erroneous state disappears, the alarm signal will turn to passive again. However, the signal will always be active for a minimum of 100 ms when triggered.

**PVEH, Fault Monitoring  
 (continued)**

To prevent the electronics from going into an undefined state, a general supervision of the power supply and the internal clock frequency is made. This function applies to PVEH - and will not activate fault monitoring:

*1. High supply voltage*

The solenoid valves are disabled when the supply voltage exceeds 36 V, and the main spool will return/stay in neutral.

*2. Low supply voltage*

The solenoid valves are disabled when the supply voltage falls below 8.5 V, and the main spool will return/stay in neutral.

*3. Internal clock*

The solenoid valves are disabled when the internal clock frequency fails, and the main spool will return/stay in neutral.

**▲ Warning**

It's up to the customer to decide on the required degree of safety for the system.

Different degrees of safety are described on *pages 34 to 37*.

The fault monitoring does not work if the supply voltage to PVEH is cut off - for example by a neutral position switch.

When using PVEH with passive fault monitoring it is up to the customer to decide on the degree of safety required for the system (*see page 34*).

**Fault Monitoring  
 Specification**

Type	Fault	Delay before error out	Error mode	Error output status	Fault output on PVE <sup>1)</sup>	LED light	Memory (reset needed)
PVEO	No fault monitoring	-	-	-	-	-	-
PVEH	Active	500 ms	No fault	Low	< 2V	Green	-
			Input signal faults	High	~U <sub>DC</sub>	Flashing red	Yes
			Transducer (LVDT)			Constant red	
	Close loop fault						
	Passive	250 ms	No fault	Low	< 2V	Green	-
			Input signal faults	High	~U <sub>DC</sub>	Flashing red	No
Transducer (LVDT)			Constant red				
Close loop fault							

<sup>1)</sup> Measured between fault output pin and ground.

**PVEH, Connection to  
 Fault Monitoring Output**

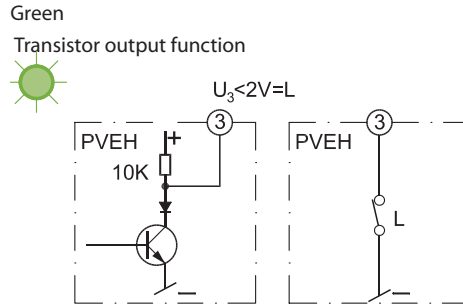

**Normal**

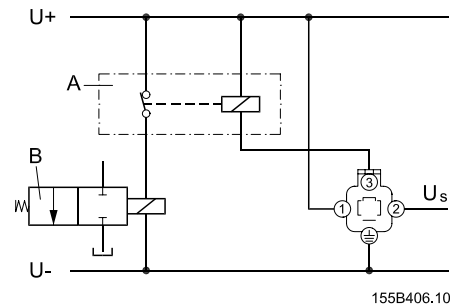

A: External relay  
 B: Solenoid valve (e.g. PVPE)

**Fault**

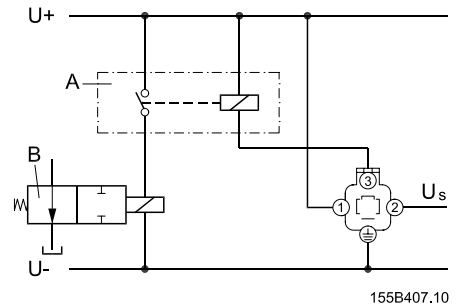
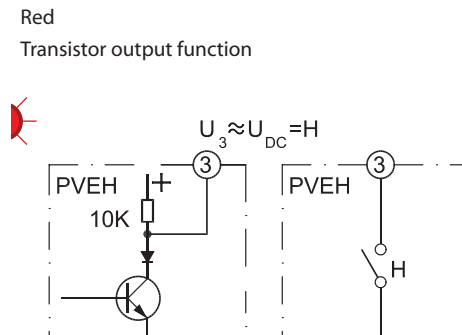

A: External relay  
 B: Solenoid valve (e.g. PVPE)

Via an external relay pin 3 can be connected to an electrically actuated valve which will relieve pump oil flow to tank, e.g. PVPE.

Other connections possible:

- a valve to relieve the LS signal
- a signal lamp, an alarm horn
- pump cut-out, etc.

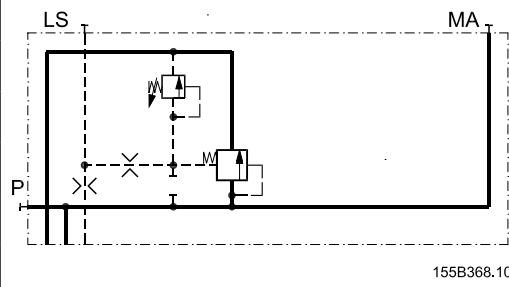
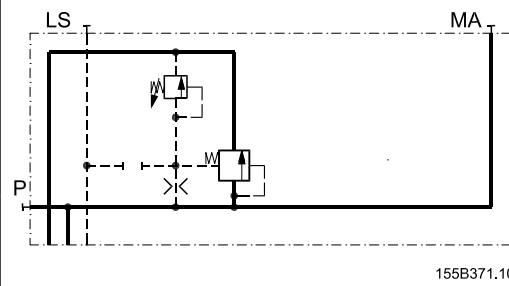
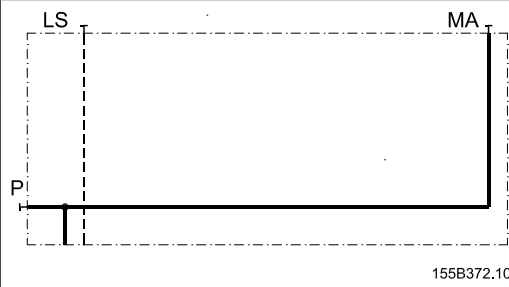

**PVP and PVPV, Pump Side Modules**

Symbol	Description		Code number
	Open centre PVP for pumps with fixed displacement. Pressure gauge connection.	Metric flange	155G5021
		SAE flange	155G5037
		O-ring boss	155G5023
	Open centre PVP for oil flow exceeding 180 l/min. [47.55 US gallon/min]. For pumps with fixed displacement. Pressure gauge connection	Metric flange	155G5027
		SAE flange	155G5029
		O-ring boss	155G5028
	Closed centre PVP for pumps with variable displacement. Pressure gauge connection.	Metric flange	155G5020
		SAE flange	155G5038
		O-ring boss	155G5022
	Closed centre PVPV without pressure relief valve. For pumps with variable displacement. Pressure gauge connection	Metric flange	155G5030
		SAE flange	155G5032
		O-ring boss	155G5031

Port connections: P = 1 in SAE flange (415 bar [6020 psi]); MA = G 1/4; LS = G 3/8

P = 1<sup>1/16</sup> - 12 UN O-ring Boss 6020 psi; MA = 1/2 - 20 UNF O-ring Boss; LS = 3/4 - 16 UNF O-ring Boss

**PVP, Accessories for Open Centre Pump Side Modules**

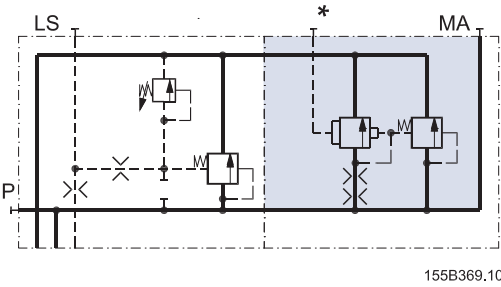
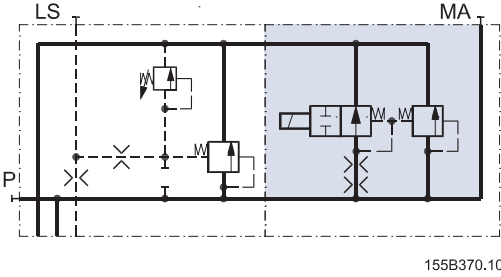
Symbol	Description	Code number
	Prop, PVPD	155G5041
	PVEH, hydraulically actuated relief valve	155G5061*
	PVPE, electrically actuated relief valve.	(12 V $\overline{\text{---}}$ ) 155G5052
	Normally open solenoid valve	(24 V $\overline{\text{---}}$ ) 155G5054

\* Connection for external pilot pressure: only available with G 1/4 thread

**PVB, Basic Modules**

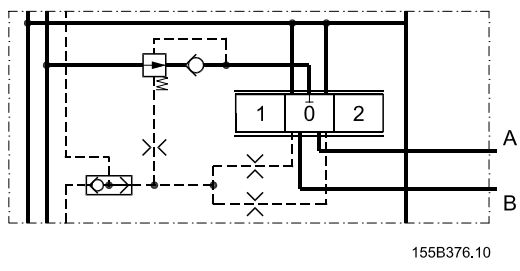
Symbol	Description	Code number	
		No facilities for shock valves A/B (low modules)	Facilities for shock valves A/B (high modules)
	Metric flange	155G6014	155G6005
	Pressure compensated basic module SAE flange	155G6016	155G6007
	O-ring boss	155G6015	155G6006

Port connections: A/B:  $\frac{3}{4}$  in SAE flange 415 bar (6020 psi);  
 A/B: 1  $\frac{1}{16}$  - 12 UN O-ring Boss 415 bar (6020 psi)

**PVB, Accessories for Basic Modules**

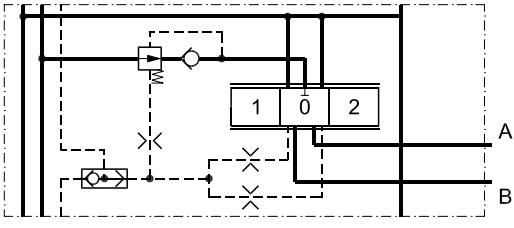
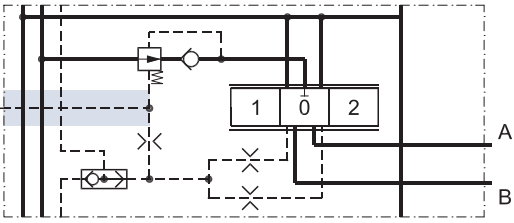
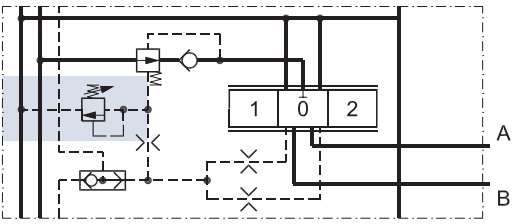
Symbol	Description	Code number
 <p>155B376.10</p>	<p>PVBP, plug</p>	<p>155G6081</p>
 <p>155B436.10</p>	<p>PVBU, module for oil flow exceeding 180 l/min [47.6 US gallon/min]. Connection for external LS pressure relief.</p>	<p>155G6035</p>
 <p>155B377.10</p>	<p>PVBR, LS-pressure relief valve for ports A/B-port</p>	<p>155G6080</p>

Port connections: G 1/4; only available with G 1/4 thread



**PVLP, Shock and Suction Valves for A and B Port Connections**

Symbol	Fixed setting		Code number
	bar	[psi]	
	50	[725]	155G0050
	75	[1100]	155G0075
	100	[1450]	155G0100
	125	[1800]	155G0125
	150	[2200]	155G0150
	175	[2550]	155G0175
	200	[2900]	55G0200
	225	[3240]	155G0225
	250	[3650]	155G0250
	275	[4000]	155G0275
	300	[4350]	155G0300
	325	[4700]	155G0325
	350	[5100]	155G0350
	375	[5450]	155G0375
	400	[5800]	155G0400

**PVLA, Suction Valve**

Symbol	Code number
	155G1065

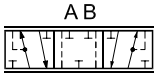
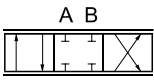
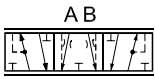
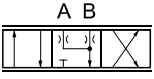
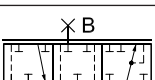
### PVBS, Main Spools

Symbol	ISO Symbol	Description	Code number Size			
			A 65 l/min [17.2 US gal/min]	B 95 l/min [25.1 US gal/min]	C 130 l/min [34.3 US gal/min]	D <sup>1)</sup> 180 l/min [47.6 US gal/min]
 A B T P T 155B235.10	 A B P T 155B384.10	4-way, 3-position. Closed neutral position	155G6452	155G6454	155G6456	155G6458
 A B T P T 155B236.10	 A B P T 155B385.10	4-way, 3-position. Throttled, open neutral position		155G6464	155G6466	155G6468
 X B T P T 155B226.10	 B P T 155B386.10	3-way, 3-position P → B			155G6476	155G6478

1) Main spool D is used for oil flow exceeding 180 l/min [47.6 US gal/min]

### PVM, Mechanical Actuation

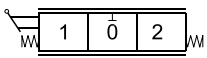
Symbol	Description	Code number
 155B387.10	PVM, standard, spring centered mechanical actuation. Individual oil flow adjustment to ports A and B.	22,5° 155G3040
		37,5° 155G3041
	PVM, mechanical actuation for hydraulically operated valves. Individual oil flow adjustment to ports A and B.	22,5° 155G3050
		37,5° 155G3051

### PVMD, Cover for Mechanical Actuation

Symbol	Description	Code number
	PVMD, cover for purely mechanically operated valve.	155G4061

### PVH, Hydraulic Actuation

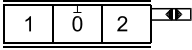
Symbol	Description	Code number
 155B339.10	PVH, cover for hydraulically operated valve.	G 1/4 155G4022
		1/2 in-20 UNF 155G4021

### PVHC, High Current Actuator

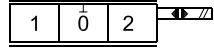
Symbol	Description	Code number		
		Hirschmann	AMP	Deutsch
 155B388.10	12 V	-	-	11110597
	24 V	-	-	11110598

### PVE, Electrical Actuation

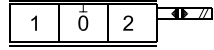
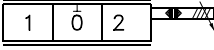
Symbol	Description	Code number		
		Hirschmann	AMP	Deutsch
 155B388.10	12 V	155G4272	155G4282	11110601
	24 V	155G4274	155G4284	11110652
 155B389.10	PVEH, Proportional high. Puls width modulation, short reaction time, low hysteresis, <b>active</b> fault monitoring, inductive transducer	155G4092	155G4094	-
	PVEH, Proportional high. Puls width modulation, short reaction time, low hysteresis, <b>passive</b> fault monitoring, inductive transducer	155G4093	155G4095	11111206
	PVES Proportional Super. Puls width modulation, short reaction time, 0% hysteresis <b>passive</b> fault monitoring, inductive transducer	11111210	-	11111207
	PVED-CC, CANbus SAE J 1939/ISOBUS	-	11111117	11111113

**PVT, Tank Side Modul**

Symbol	Description		Code number
Upper part  155B380.10	Upper part: Without active elements	Metric flange	155G7020
		SAE flange	155G7022
		O-ring boss	155G7021
	Upper part: With LX connection	Metric flange	155G7023
		SAE flange	155G7025
		O-ring boss	155G7024
Lower part  155B435.10	Lower part: Without active elements	Mounting	155G7060
		Mounting thread UNF	155G7062
Lower part  155B381.10	Lower part: PVE, pilot oil supply for electrical actuations. Filter mesh: 125µm	Mounting thread metric	155G7040
		Mounting thread UNF	155G7042
Lower part  155B381.10	Lower part: PVH, pilot oil supply for hydraulic actuations. Filter mesh: 125µm	Mounting thread metric	155G7043
		Mounting thread UNF	155G7044

Port connections: T = 1 in SAE flange 210 bar [3045 psi]; PP = G 3/8 [3/8 in SAE] LX = G 3/8 [3/8 in SAE].

T = 15/16 - 12 UN O-ring Boss 3045 psi; PP = 3/4 - 16 UNF O-ring Boss; LX = 3/4 - 16 UNF O-ring Boss

**PVAS, Assembly Kit**

	Code number 155G...							
	1 PVB	2 PVB	3 PVB	4 PVB	5 PVB	6 PVB	7 PVB	8 PVB
Tie bolts and seals	155G8031	155G8032	155G8033	155G8034	155G8035	155G8036	155G8037	155G8038



**Modules for Oil Flow  
Exceeding 180 l/min  
[47.6 US gal/min]****Pump with fixed displacement**

## 1. Ordering:

Order accessory module 155G6035, main spool D, and pump side modules 155G5027/155G5028/155G5029

## 2. Conversion:

In open centre systems a max. oil flow exceeding 180 l/min [47.6 US gal/min] is achieved by changing the following parts in the pump side and basic modules:

- Open centre pump side module
  - a. Pressure adjustment spool
  - b. The springs behind the pressure adjustment spool
  - c. The plug behind the pressure adjustment spoolParts from kit 155G5035 may be used.

- Closed centre pump side module

A closed centre pump side module can be changed into an upgraded open centre pump side module by means of kit 155G5035.

- Basic module
  - d. Spring behind pressure compensator
  - e. The plug behind the pressure compensator

Spring and plug with code number 155G6035 (PVBU, accessory module).

**Pump with variable displacement**

## 1. Ordering:

Order accessory module 155G6035 and main spool D.

## 2. Conversion:

In closed centre systems a max. oil flow exceeding 180 l/min [47.6 US gal/min] can be achieved by changing the following basic module parts:

- a) Spring behind pressure compensator
- b) The plug behind the pressure compensator

The code number of the spring and plug is 155G6035 (PVBU, accessory module).

**General**

All characteristics and values in this Technical Information are typical measured results. For the hydraulic system a mineral based hydraulic oil with a viscosity of 21mm<sup>2</sup>/s [102 SUS] and a temperature of 50°C [122°F] was used.

**PVP, Pump Side Module**

*PVP, pressure relief valve characteristic*

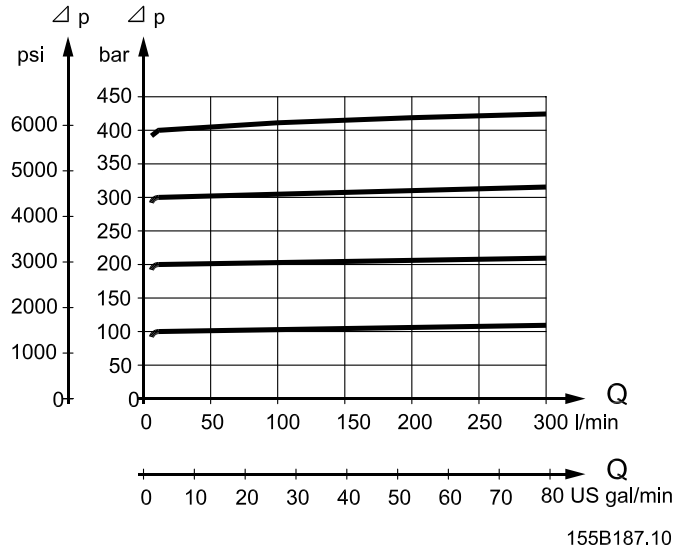

The pressure relief valve is adjustable within the 50-400 bar [725-6225 psi] range by means of a screw.

*PVP, neutral flow pressure in PVP, open centre*

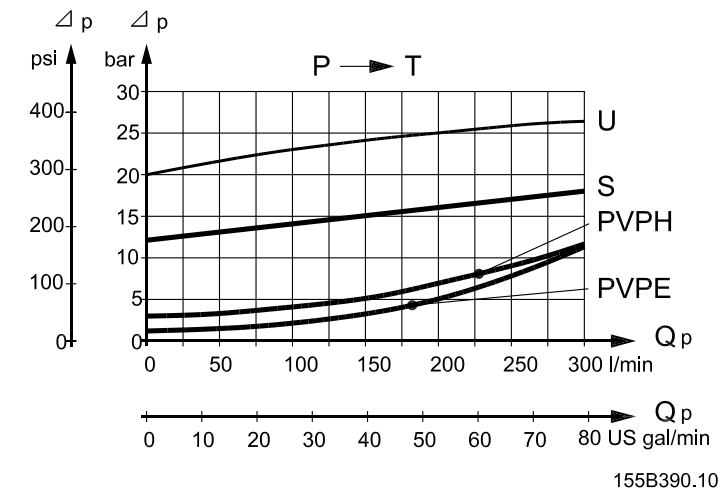

U = PVP for PVB oil flow > 180 l/min [47.6 US gal/min]  
 S = PVP, standard

PVB, Basic Module

Oil flow characteristics

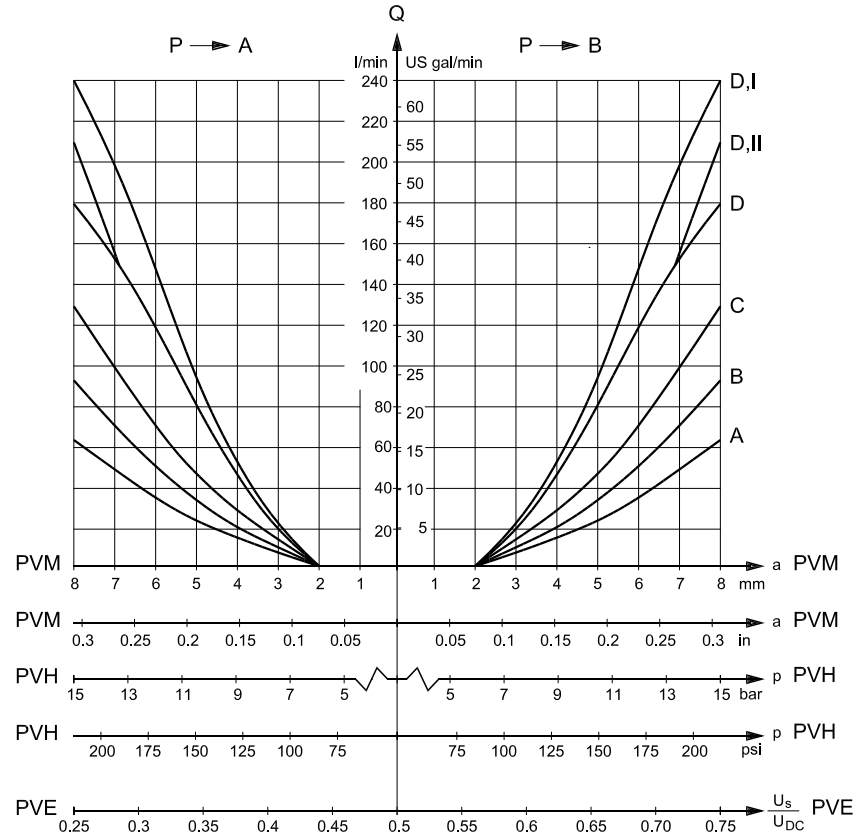

155B397.10

- A : 65 l/min [17.2 US gal/min] rated oil flow
- B : 95 l/min [25.1 US gal/min] rated oil flow
- C : 130 l/min [34.3 US gal/min] rated oil flow
- D : 180 l/min [47.6 US gal/min] rated oil flow
- D.I : 240 l/min [63.4 US gal/min] rated oil flow  
 (Closed centre system with basic module for oil flow > 180 l/min [47.6 US gal/min])
- D.II : 210 l/min [55.5 US gal/min] rated oil flow  
 (Open centre system with basic module for oil flow > 180 l/min [47.6 US gal/min] and pump side module 155G5027/155G5028/155G5029).

$U_s$  = Signal voltage  
 $U_{DC}$  = Supply voltage

**PVB, Basic Module**

*Load independent oil flow*

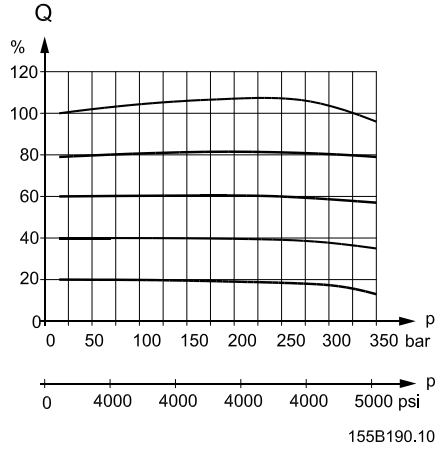

Pressure drop (Q) T in neutral position  
 (spools with open neutral position) (p)

The oil flow (Q) is shown as a function of  
 the load (p).

*Pressure drop A/B → T at full spool travel*

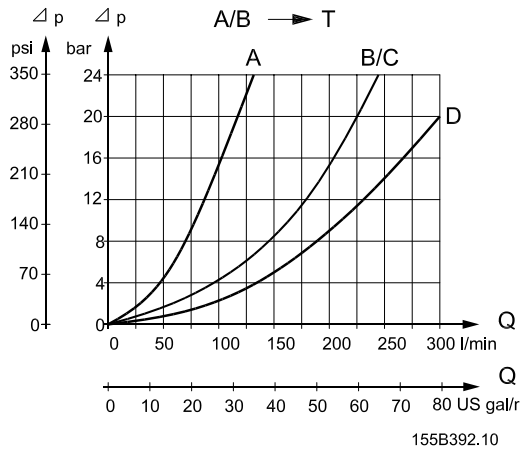

*Pressure drop A/B → T in neutral position  
 (spools with open neutral position)*

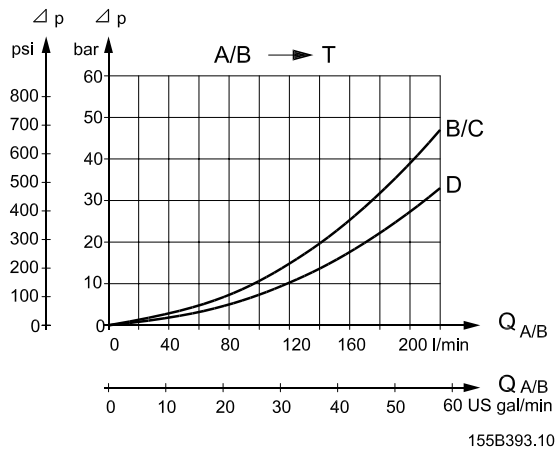

**PVLP, Shock Valve  
 (Pressure Relief Valve in  
 PVLP)**

The shock valve PVLP is designed to absorb shock effects. Consequently, it shall not be used as a pressure relief valve.

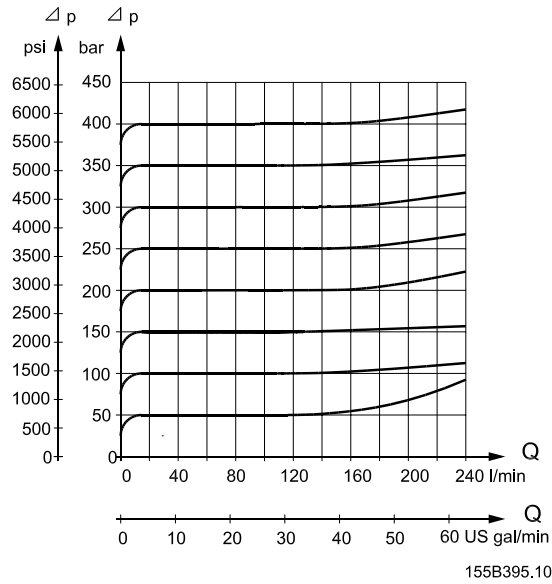

**PVLP/PVLA, Suction  
 Function**

*PVLP/PVLA, suction function characteristics*

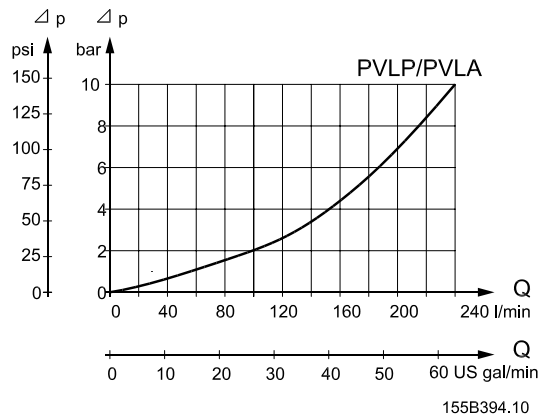

Valve Dimensions

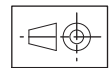
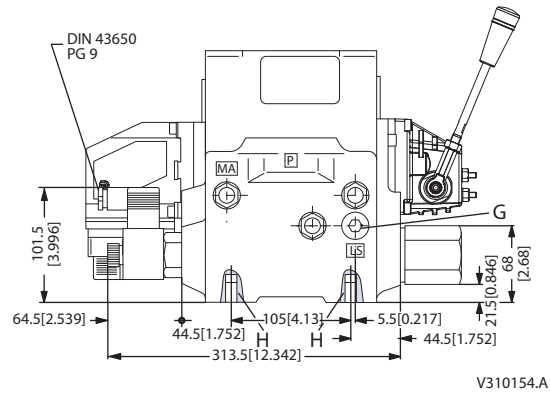
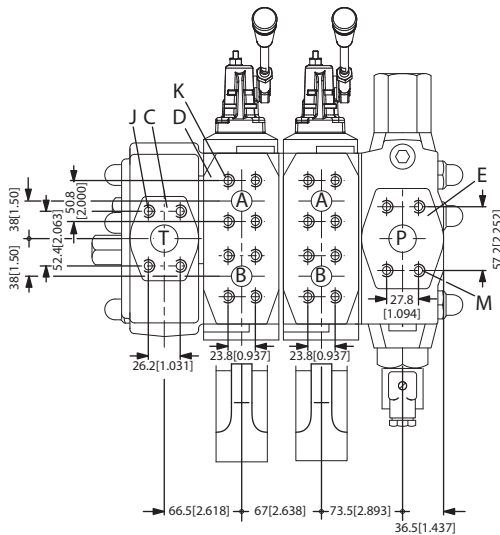
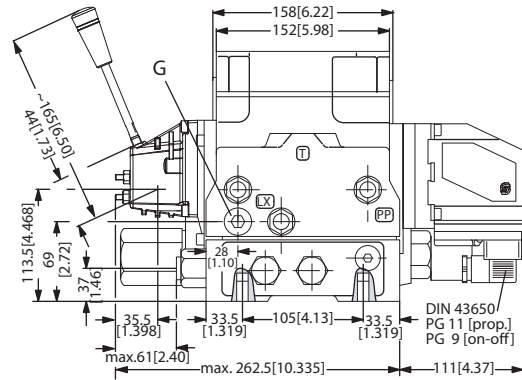
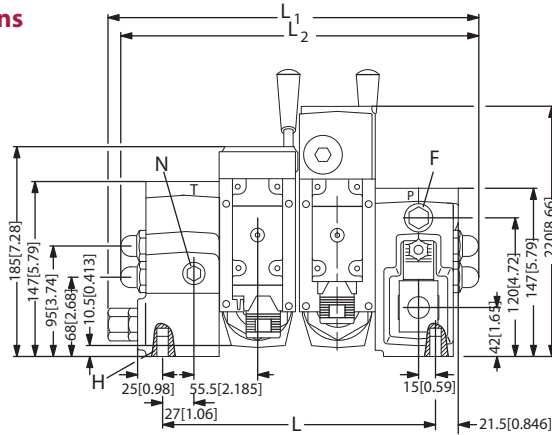

V310153.B

- C : 1 in SAE flange (210 bar) – [1 in SAE flange/1 5/16 - 12 UN O-ring Boss (3045 psi)]
- D : 3/4 in SAE flange (415 bar) – [3/4 in SAE flange/1 1/16 - 12 UN O-ring Boss (6020 psi)]
- E : 1 in SAE flange (415 bar) – [1 in SAE flange/1 5/16 - 12 UN O-ring Boss (6020 psi)]
- F : G 1/4 – [1/2 in - 20 UNF]
- G : G 3/8 – [3/4 in - 16 UNF]
- H : M12; 18 mm deep – [7/16 - 14 UNC; 0.7 in deep]
- J : M10; 17 mm deep – [3/8 - 16 UNC; 0.7 in deep]
- K : M10; 17 mm deep – [3/8 - 16 UNC; 0.7 in deep]
- M : M12; 18 mm deep – [7/16 - 14 UNC; 0.7 in deep]
- N : G 3/8 – [3/4 in - 16 UNF]

	PVB	1	2	3	4	5	6	7	8
L	mm	170	237	304	371	438	505	572	639
	in	[6.69]	[9.33]	[11.97]	[14.61]	[17.24]	[19.88]	[22.51]	[25.16]
L1	mm	263.5	330.5	397.5	464.5	531.5	598.5	665.5	732.5
	in	[10.38]	[13.02]	[15.66]	[18.30]	[20.94]	[23.58]	[26.22]	[28.86]
L2	mm	255	322	389	456	523	590	657	724
	in	[10.05]	[12.69]	[15.33]	[17.97]	[20.61]	[23.25]	[25.89]	[28.53]

General Dimensions

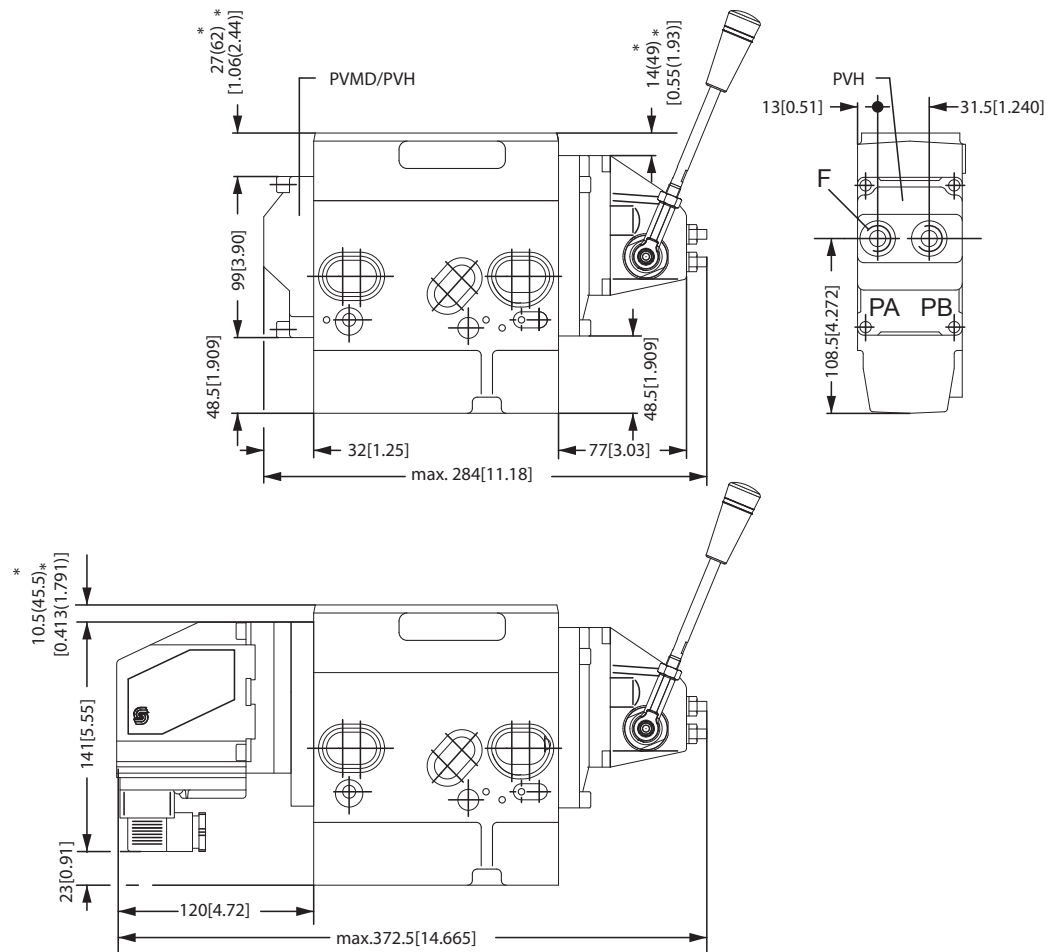

F : G 1/4 [1/2 in - 20 UNF]

\* Dimensions in parenthesis apply to high basic modules

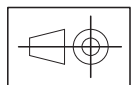

V310103.A

**PVM, Lever Positions**

*Base with an angle of 37.5°*

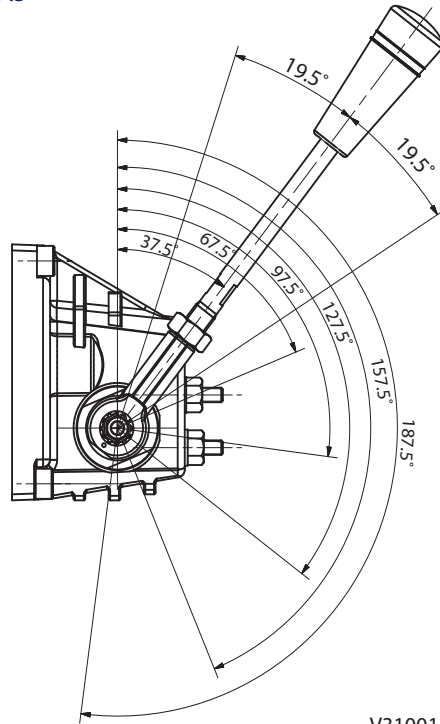

V310018.A

*Base with an angle of 22.5°*

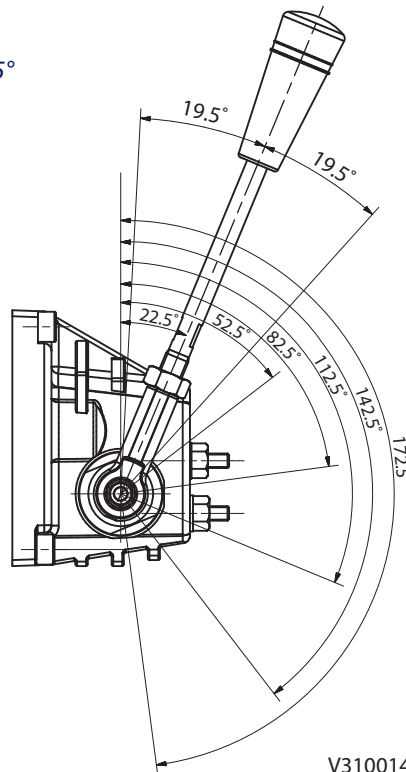

V310014.A



**Building in Safety**

All makes and all types of control valves (incl. proportional valves) can fail. Thus the necessary protection against the serious consequences of function failure should always be built into the system. For each application an assessment should be made for the consequences of pressure failure and uncontrolled or blocked movements.

To determine the degree of protection that is required to be built into the application, system tools such as an FMEA (Failure Mode and Effect Analysis) and Hazard and Risk Analysis can be used.

**FMEA (Failure Mode and Effect Analysis) IEC EN 61508**

FMEA is a tool used for analyzing potential risks. This analytical technique is utilized to define, identify, and prioritize the elimination or reduction of known and/or potential failures from a given system before it is released for production.

Please refer to IEC FMEA Standard 61508.

**Hazard and Risk Analysis ISO 12100-1 / 14121**

This analysis is a tool used in new applications as it will indicate whether there are special safety considerations to be met according to the machine directives EN 13849. Dependent on the determined levels conformity this analysis will determine if any extra requirements for the product design, development process, production process or maintenance, i.e. the complete product life cycle.

** Warning**

---

All makes/brands and types of directional control valves – inclusive proportional valves – can fail and cause serious damage. It is therefore important to analyze all aspects of the application.

Because the proportional valves are used in many different operation conditions and applications, the manufacturer of the application is alone responsible for making the final selection of the products – and assuring that all performance, safety and warning requirements of the application are met.

The process of choosing the control system – and safety levels – is governed by the machine directives EN 13849 (Safety related requirements for control systems).

---

**Control System Example**

Example of a control system for manlift using PVE Fault monitoring input signals and signals from external sensors to ensure the PLUS+1™ main controllers correct function of the manlift.

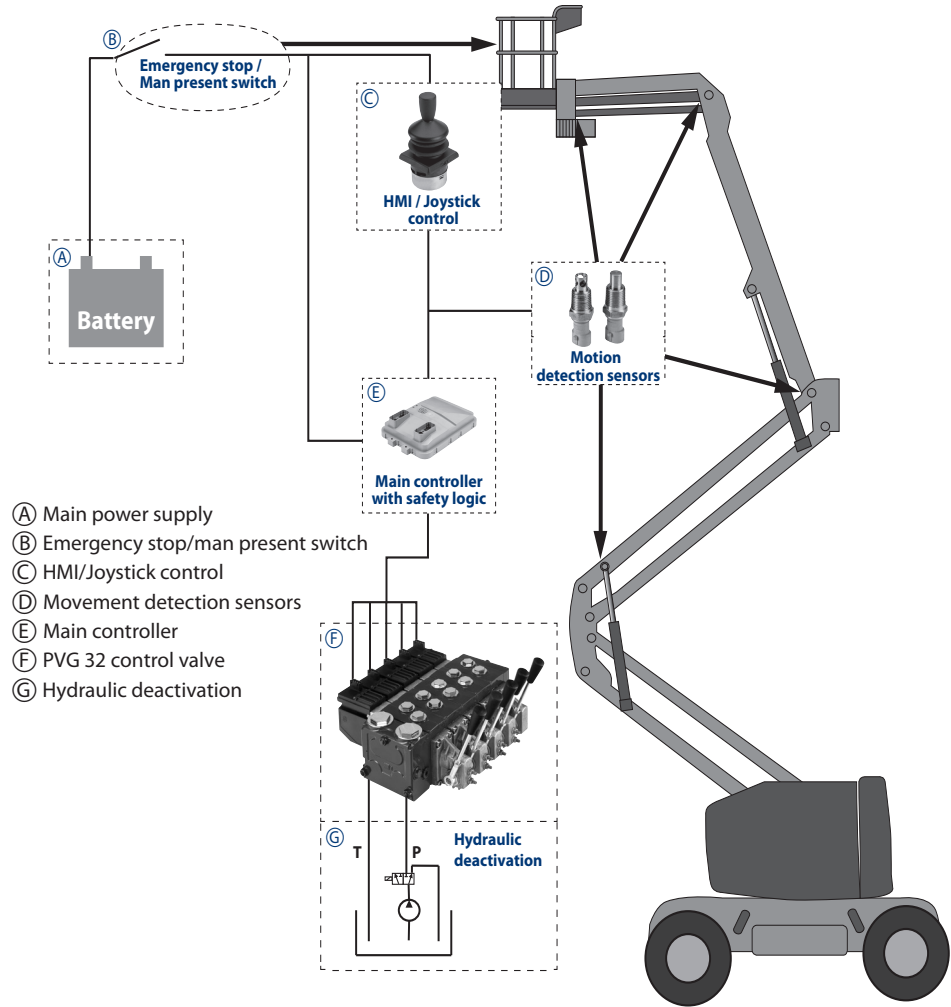

P301 316

*Electrical block diagram for above illustration*

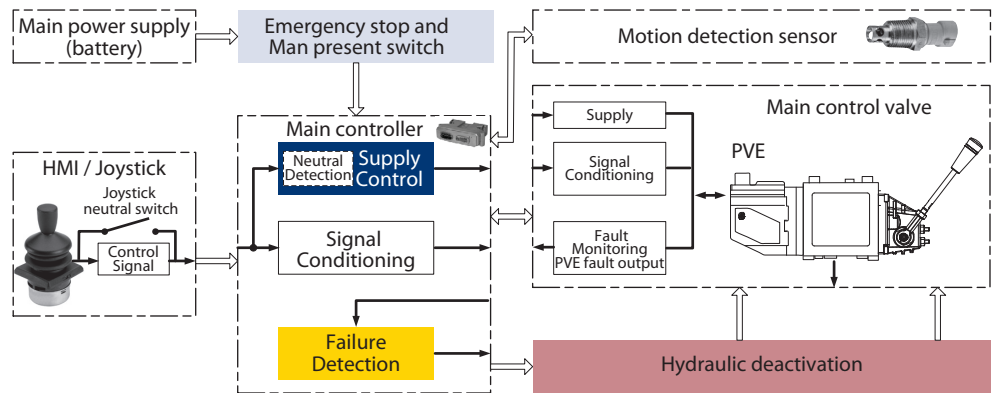

P301 317

**Warning**

It is the responsibility of the equipment manufacturer that the control system incorporated in the machine is declared as being in conformity with the relevant machine directives.

**Control System Example  
 (continued)**

*Example of a typical wiring block diagram using PVEH with neutral power off switch and fault monitoring output for hydraulic deactivation.*

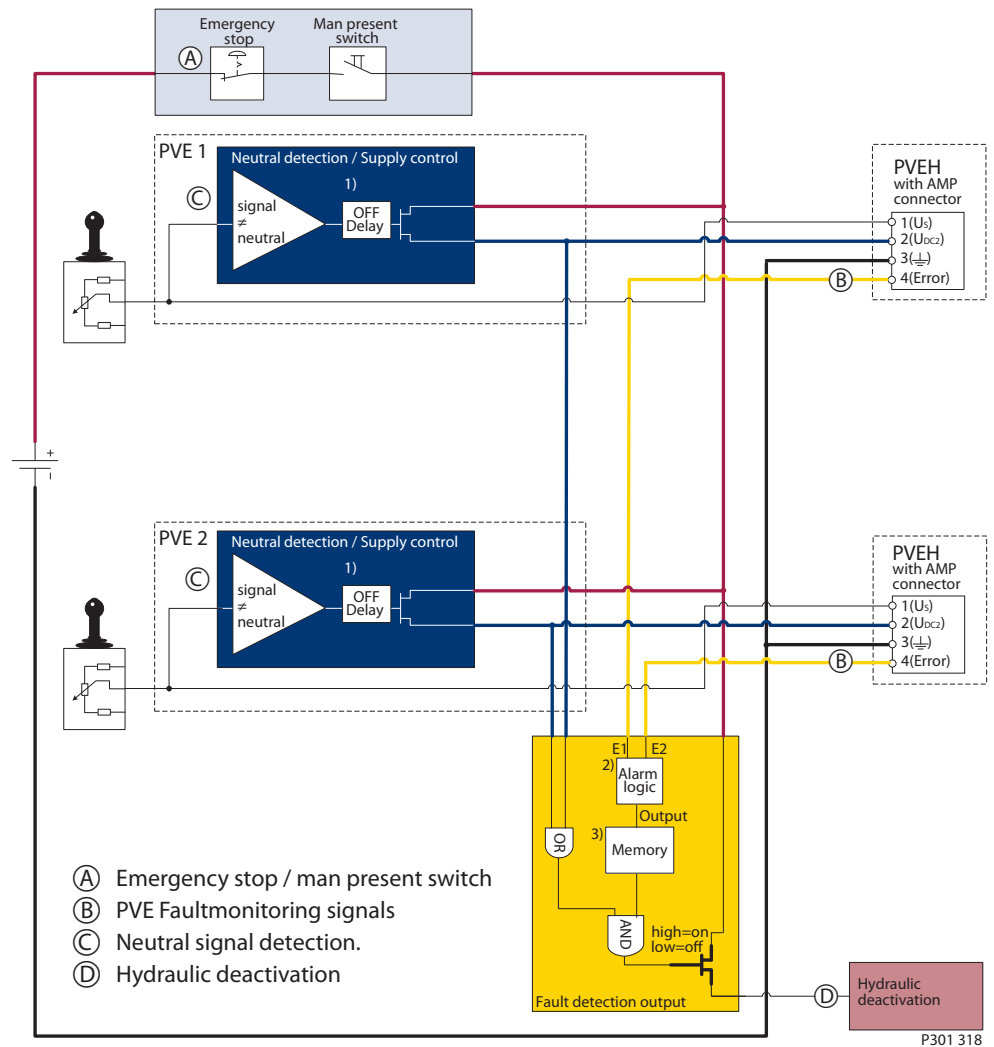

P301 318

System Control Logic e.g. PLUS+1™ for signal monitoring and triggering signal for deactivation of the hydraulic system.

**Warning**

It is the responsibility of the equipment manufacturer that the control system incorporated in the machine is declared as being in conformity with the relevant machine directives.

**Control System Example  
 (continued)**

Example of fault monitoring for deactivation of the hydraulic system with extra fault inputs using the PVE's with DI (Direction Indication) function.

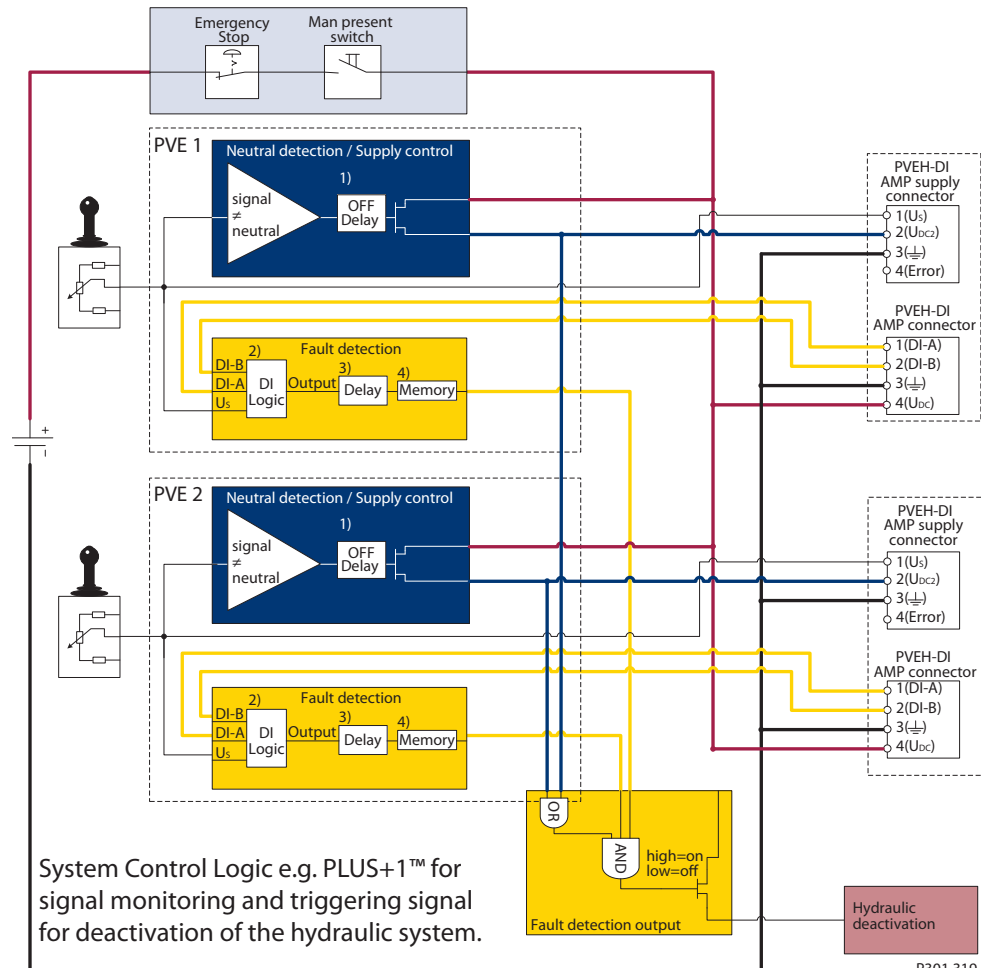

**⚠ Warning**

It is the responsibility of the equipment manufacturer that the control system incorporated in the machine is declared as being in conformity with the relevant machine directives.

Other non-electrical modules which can be used in connection with hydraulic deactivation at different levels.

**PVG32 – Mainly used in system with fixed displacement pumps**

- PVSK, commonly used in crane application - full flow dump
- PVPX, LS dump to tank

**PVG100 – Alternative LS dump or pilot supply disconnect**

- PVPP, pilot oil supply shut off
- External cartridge valve connecting LS Pressure to Tank
- External cartridge valve connecting main Pressure to Tank

**PVG120 – Pump disconnect/block for variable pumps**

- PVPE, full flow dump for the PVG 120



PVG 120 Proportional Valve  
Technical Information  
Notes

**Oil**

The main duty of the oil in a hydraulic system is to transfer energy; but it must also lubricate the moving parts in hydraulic components, protect them against corrosion, and transport dirt particles and heat out of the system. It is therefore important to choose the correct oil with the correct additives. This gives problem-free operation and long working life.

**Mineral oil**

For systems with PVG 120 valves Sauer-Danfoss recommends the use of mineral-based hydraulic oil containing additives: Type H-LP (DIN 51524) or HM (ISO 6743/4).

**Non-flammable fluids**

Phosphate-esters (HFDR fluids) can be used without special precautions. However, dynamic seals must be replaced with FPM (Viton) seals. Please contact the Sauer-Danfoss Sales Organisation if the PVG 120 valve is to be used with phosphate-esters. The following fluids should only be used according to agreement with the Sales Organisation for Sauer-Danfoss:

- Water-glycol mixtures (HFC fluids)
- Water-oil emulsions (HFB fluids)
- Oil-water emulsions (HFAE fluids)

**Biodegradable oils**

PVG 120 valves can be used in systems using rape-seed oil. The use of rape-seed oil is conditional on

- it complying with the demands on viscosity, temperature and filtration etc.  
(see chapters below and technical data page 10).
- the operating conditions being adapted to the recommendations of the oil supplier.

Before using other biodegradable fluids, please consult the Sauer-Danfoss Sales Organisation.

**Particle Content, Degree of Contamination**

Oil filtration must prevent the particle content from exceeding an acceptable level, i.e. an acceptable degree of contamination.

Maximum contamination for PVG 120 is 23/19/16 (see ISO 4406).

Calibration in accordance with the ACFTD method.

In our experience a degree of contamination of 23/19/16 can be maintained by using a filter fineness as described in the next section.

## Filtering

Effective filtration is the most important precondition in ensuring that a hydraulic system performs reliably and has a long working life. Filter manufacturers issue instructions and recommendations. It is advisable to follow them.

### System filters

Where demands for safety and reliability are very high a pressure filter with bypass and indicator is recommended. Experience shows that a 10 µm nominal filter (or finer) or a 20 µm absolute filter (or finer) is suitable.

It is our experience that a return filter is adequate in a purely mechanically operated valve system.

The fineness of a pressure filter must be selected as described by the filter manufacturer so that a particle level of 23/19/16 is not exceeded. See "Particle content, degree of contamination".

The filter must be fitted with pressure gauge or dirt indicator to make it possible to check the condition of the filter.

In systems with differential cylinders or accumulators the return filter must be sized to suit the max. return oil flow. Pressure filters must be fitted to suit max. pump oil flow.

### Internal filters

The filters built into PVG 120 are not intended to filter the system but to protect important components against large particles.

Such particles can appear in the system as a result of pump damage, hose fracture, use of quick-couplings, filter damage, starting up, contamination, etc.

The filter that protects the pilot supply in the tank side module has a mesh of 125 µm. It is obtainable as a spare part and is easy to replace.

The filter protecting the essential PVE parts has a mesh of 125 µm.

## Conversion Factors

1 Nm	=	885.1 lbf·in
1 N	=	22.48 lbf
1 bar	=	14.50 psi
1 mm	=	0.0394 in
1 cm <sup>3</sup>	=	0.061 in <sup>3</sup>
1 l	=	0.22 gallon, UK
1 l	=	0.264 gallon, US
°F	=	1.8 · °C + 32

### Order Form

An order form for Sauer-Danfoss PVG 120 hydraulic valve is shown on next page.  
The form can be obtained from the Sauer-Danfoss Sales Organisation.  
The module selection chart on the next page and the order form are divided into fields.

Each module has its own field:

- 0: PVP, pump side modules
- d: PVPD, PVPH and PVPE, accessory modules
- 1-8: PVB, basic modules
- e: PVBS, main spools
- f: PVBP, PVBR, PVBU and PVBC, accessory modules
- a: PVM, mechanical actuation
- c: PVMD, cover for mechanical operation  
PVH, cover for hydraulic operation  
PVEO and PVEH, electrical actuations
- b: PVLP, shock and suction valve  
PVLA, suction valve
- 9: PVT, tank side module
- 10: PVAS, assembly kit

*Please state:*

- Code numbers of all modules required
- Required setting (p) for pump side module
- Required setting of LS<sub>A/B</sub> pressure relief valves, if accessory module PVBR is ordered.



**Order Form**

**Reordering**

The space at the top right-hand corner of the form is for Sauer-Danfoss to fill in. The code number for the whole of the specified valve group (PVG No.) is entered here. In the event of a repeat order all you have to do is enter the number Sauer-Danfoss has given on the initial confirmation of order.

If PVG 120 is to be used with phosphate-esters this must be stated on the order form (see also page 38, "Non-flammable fluids").

**PVG 120  
 Specification Sheet**

Subsidiary / Dealer	PVG No.
Customer	Customer No.
Application	Revision No.

Function	A-Port	0	155G	155G	B-Port
		p =		bar	
	a 155G	1	155G	155G	e 155G c
	b 155G	f	155G	LS <sub>AB</sub> bar	155G b
	a 155G	2	155G	155G	e 155G c
	b 155G	f	155G	LS <sub>AB</sub> bar	155G b
	a 155G	3	155G	155G	e 155G c
	b 155G	f	155G	LS <sub>AB</sub> bar	155G b
	a 155G	4	155G	155G	e 155G c
	b 155G	f	155G	LS <sub>AB</sub> bar	155G b
	a 155G	5	155G	155G	e 155G c
	b 155G	f	155G	LS <sub>AB</sub> bar	155G b
	a 155G	6	155G	155G	e 155G c
	b 155G	f	155G	LS <sub>AB</sub> bar	155G b
	a 155G	7	155G	155G	e 155G c
	b 155G	f	155G	LS <sub>AB</sub> bar	155G b
	a 155G	8	155G	155G	e 155G c
	b 155G	f	155G	LS <sub>AB</sub> bar	155G b
Remarks		9	155G		
		10	155G		
		11	155G		

Filled in by	Date
--------------	------

991L1888 ver. 03.2002

*PVB, high basic module*

	SAE flange	O-ring Boss	Metric flange	Weight kg [lb]
Facilities for shock valves AB	155G6007	155G6006	155G6005	10.2 [22.5]

*PVB, low basic module*

	SAE flange	O-ring Boss	Metric flange	Weight kg [lb]
No facilities for shock valves AB	155G6016	155G6015	155G6014	8.9 [19.6]

*Accessory modules for PVB*

	Weight kg [lb]
Plug, PVBP	155G6081 0.4 [0.9]
LSA/B press. relief valve, PVBR	155G6080 0.4 [0.9]
External LS connection, PVBC	155G6082 0.4 [0.9]
Module for oil flow > 180 l/min [47.6 US gal/min], PVBU	155G6035 0.4 [0.9]

*PVBS, mechanical actuation*

Oil flow l/min [US gal]	Symbol				
	A	B	C	D	
65 [17.2]	155G6452	155G6454	155G6456	155G6458	
95 [25.1]	-	155G6464	155G6466	155G6468	
130 [34.3]	-	-	155G6476	155G6478	
180 [47.6]	-	-	-	-	
Weight	kg [lb]	0.35 [0.8]	0.35 [0.8]	0.35 [0.8]	0.35 [0.8]

*PVM, mechanical actuation*

PVM + PVMD or PVM + PVE	155G3040
PVM + PVH	155G3050
Weight	0.5 kg [1.1 lb]

*PVT, tank side module*

	SAE flange	O-ring Boss	Metric flange	Weight kg [lb]
Upper part excl. LX connection	155G7022	155G7021	155G7020	4.6 [10.1]
Upper part incl. LX connection	155G7025	155G7024	155G7023	4.6 [10.1]
Lower part incl. pilot oil supply PVE for		155G7042	155G7040	4.4 [9.7]
Lower part excl. pilot oil supply for PVE		155G7062	155G7060	4.4 [9.7]
Lower part incl. pilot oil supply for PVH		155G7044	155G7043	4.4 [9.7]

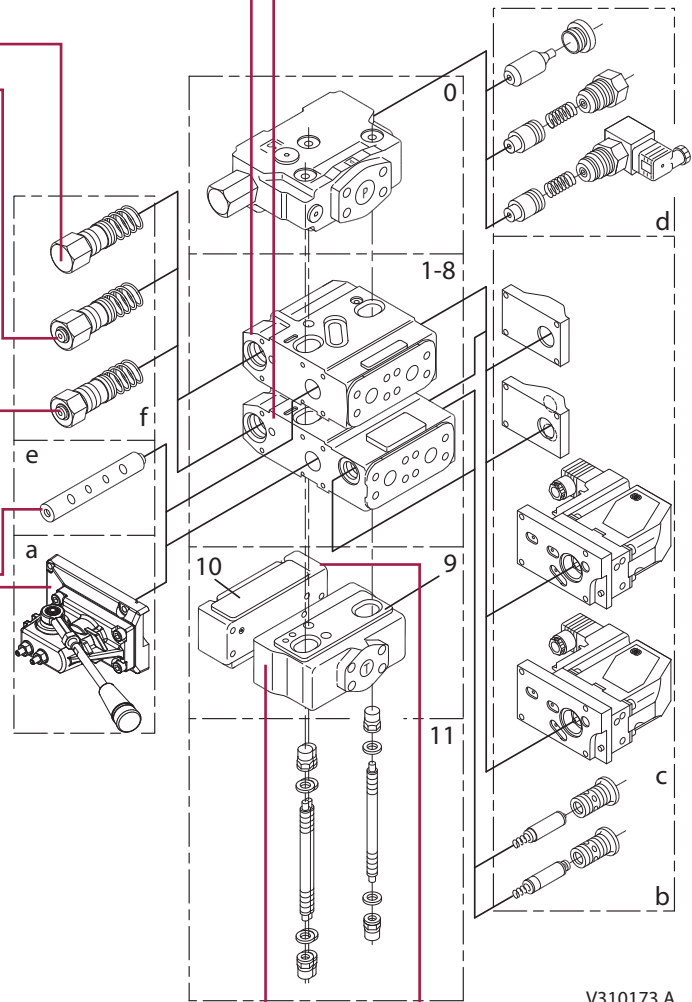

*PVP, pump side module*

		O-ring Boss	SAE flange	Metric flange	Weight kg [lb]
Open centre	Excl. PVPD, PVPH, PVPE	155G5023	155G5037	155G5021	10.0 [22.1]
	For PVB-oil flow > 180 l/min [47.6 US gal/min] Excl. PVPD, PVPH, PVPE	155G5028	155G5029	155G5027	10.0 [22.1]
Closed centre	Incl. pressure relief valve and plug PVPD	155G5022	155G5038	155G5020	10.2 [22.5]
	Excl. pressure relief valve	155G5031	155G5032	155G5030	11.0 [24.3]

*Accessory modules for open centre PVP*

		Weight kg [lb]
Plug, PVPD	155G5041	0.4 [0.9]
Hydraulic relief valve, PVH	155G5061	0.5 [1.1]
Electrical relief valve, PVPE	12 V	0.7 [1.5]
	24 V	0.7 [1.5]

*PVMD, cover for PVM*

	Weight kg [lb]
155G4061	0.3 [0.7]

*PVH, cover for PVRHH*

		Weight kg [lb]
1/2 in - 20 UNF	155G4021	0.4 [0.9]
G 1/4	155G4022	0.4 [0.9]

*Electrical actuation PVE*

Connector	PVEH 11 - 32 V Fault monitoring		PVEO		
	Active	Passive	12 V	24 V	
Hirschmann	155G4092	155G4093	155G4272	155G4274	
AMP	155G4094	155G4095	155G4282	155G4284	
Weight	kg	1.25	1.25	1.0	1.0
	[lb]	[2.76]	[2.76]	[2.2]	[2.2]

*PVLA suction valve A/B*

	Weight kg [lb]
155G1065	0.2 [0.4]

*PVLP, shock and suction valve A/B*

Pressure setting		
bar	[psi]	
50	725	155G0050
75	1100	155G0075
100	1450	155G0100
125	1800	155G0125
150	2200	155G0150
175	2550	155G0175
200	2900	155G0200
225	3250	155G0225
250	3650	155G0250
275	4000	155G0275
300	4350	155G0300
325	4700	155G0325
350	5100	155G0350
375	5400	155G0375
400	5800	155G0400
Weight	kg	0.175
	[lb]	[0.386]

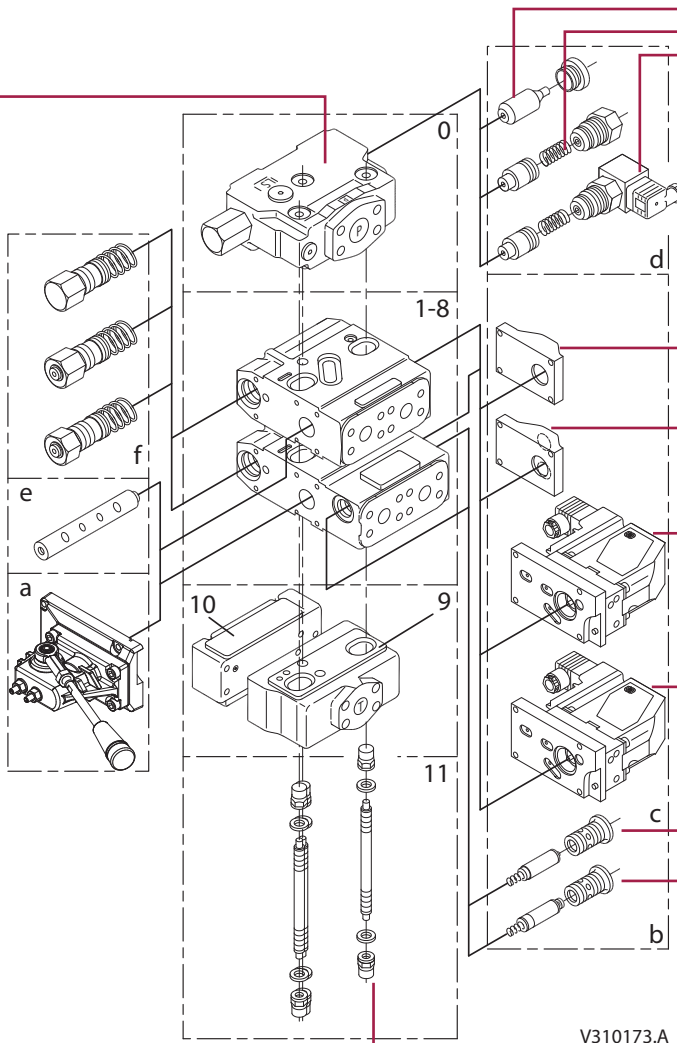

V310173.A

*PVAS, assembly kit*

PVB's		1	2	3	4	5	6	7	8
		155G8031	155G8032	155G8033	155G8034	155G8035	155G8036	155G8037	155G8038
Weight	kg	0.8	1.0	1.1	1.2	1.4	1.7	1.9	2.1
	[lb]	[1.8]	[2.2]	[2.4]	[2.6]	[3.1]	[3.7]	[4.2]	[4.6]



**Products we offer:**

- Bent Axis Motors
- Closed Circuit Axial Piston Pumps and Motors
- Displays
- Electrohydraulic Power Steering
- Electrohydraulics
- Hydraulic Power Steering
- Integrated Systems
- Joysticks and Control Handles
- Microcontrollers and Software
- Open Circuit Axial Piston Pumps
- Orbital Motors
- PLUS+1™ GUIDE
- Proportional Valves
- Sensors
- Steering
- Transit Mixer Drives

**Members of the Sauer-Danfoss Group:**

**Comatrol**

[www.comatrol.com](http://www.comatrol.com)

**Schwarz Müller-Inverter**

[www.schwarzmueller-inverter.com](http://www.schwarzmueller-inverter.com)

**Turolla**

[www.turollaocg.com](http://www.turollaocg.com)

**Valmova**

[www.valmova.com](http://www.valmova.com)

**Hydro-Gear**

[www.hydro-gear.com](http://www.hydro-gear.com)

**Sauer-Danfoss-Daikin**

[www.sauer-danfoss-daikin.com](http://www.sauer-danfoss-daikin.com)

**Sauer-Danfoss** is a global manufacturer and supplier of high-quality hydraulic and electronic components. We specialize in providing state-of-the-art technology and solutions that excel in the harsh operating conditions of the mobile off-highway market. Building on our extensive applications expertise, we work closely with our customers to ensure exceptional performance for a broad range of off-highway vehicles.

We help OEMs around the world speed up system development, reduce costs and bring vehicles to market faster.

Sauer-Danfoss – Your Strongest Partner in Mobile Hydraulics.

**Go to [www.sauer-danfoss.com](http://www.sauer-danfoss.com) for further product information.**

Wherever off-highway vehicles are at work, so is Sauer-Danfoss.

We offer expert worldwide support for our customers, ensuring the best possible solutions for outstanding performance. And with an extensive network of Global Service Partners, we also provide comprehensive global service for all of our components.

Please contact the Sauer-Danfoss representative nearest you.

Local address:

Sauer-Danfoss (US) Company  
2800 East 13th Street  
Ames, IA 50010, USA  
Phone: +1 515 239 6000  
Fax: +1 515 239 6618

Sauer-Danfoss ApS  
DK-6430 Nordborg, Denmark  
Phone: +45 7488 4444  
Fax: +45 7488 4400

Sauer-Danfoss GmbH & Co. OHG  
Postfach 2460, D-24531 Neumünster  
Krokamp 35, D-24539 Neumünster, Germany  
Phone: +49 4321 871 0  
Fax: +49 4321 871 122

Sauer-Danfoss-Daikin LTD.  
Shin-Osaka TERASAKI 3rd Bldg. 6F  
1-5-28 Nishimiyahara, Yodogawa-ku  
Osaka 532-0004, Japan  
Phone: +81 6 6395 6066  
Fax: +81 6 6395 8585