

A Wide Range of  
 Hydraulic Motors

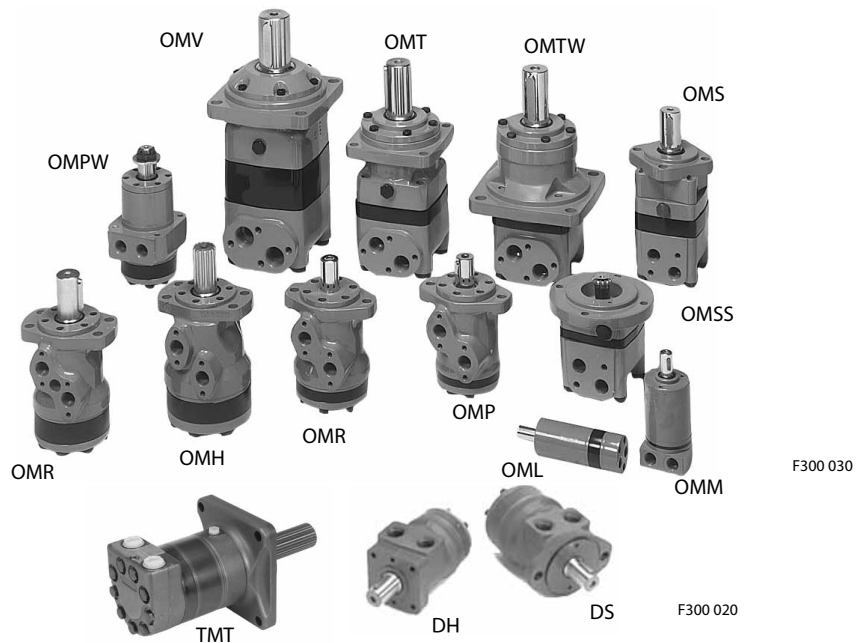

Sauer-Danfoss is Europe's largest producer of high torque low speed hydraulic motors. We can offer more than 1600 different hydraulic motor versions categorised in types, variants and sizes.

The motors vary in size [rated displacement] from 8 cm<sup>3</sup> [0,49 in<sup>3</sup>] to 800 cm<sup>3</sup> [48,91 in<sup>3</sup>] per revolution. Speeds range up to approx. 2500 min<sup>-1</sup> for the smallest type and up to approx 600 min<sup>-1</sup> for the largest type.

Maximum operating torques vary from 13 Nm [115 lbf·in] to 2700 Nm [24.000 lbf·in] peak and maximum outputs are from 2,0 kW [2,7 hp] to 70 kW [95 hp].

Characteristic features:

- Smooth running over the entire speed range
- Constant operating torque over a wide speed range
- High starting torque
- High return pressure without the use of drain line [High pressure shaft seal]
- High efficiency
- Long life under extreme operating conditions
- Robust and compact design
- High radial and axial bearing capacity
- For applications in both open and closed loop hydraulic systems
- Suitable for a wide variety of hydraulics fluids

© 2010 Sauer-Danfoss. All rights reserved.

Sauer-Danfoss accepts no responsibility for possible errors in catalogs, brochures and other printed material. Sauer-Danfoss reserves the right to alter its products without prior notice. This also applies to products already ordered provided that such alterations can be made without affecting agreed specifications. All trademarks in this material are properties of their respective owners. Sauer-Danfoss, the Sauer-Danfoss logotype, the Sauer-Danfoss S-icon, PLUS+1™, What really matters is inside® and Know-How in Motion™ are trademarks of the Sauer-Danfoss Group.

Front page: F300 028, F300 029, F300 023, F300 025, F300 026, F300 024, F300 021, F300 027, F300 023, Drawing: 151-1837

**A Wide Range of Hydraulic Motors (continue)**

The programme is characterised by technical features appealing to a large number of applications and a part of the programme is characterised by motors that can be adapted to a given application. Adaptions comprise the following variants among others:

- Motors with corrosion resistant parts
- Wheel motors with a recessed mounting flange
- OMP, OMR motors with needle bearings
- OMR motors in low leakage version
- OMR motors in a super low leakage version
- Short motors without bearings
- Ultra short motors without bearings
- Motors with integrated positive holding brake
- Motors with integrated negative holding brake
- Motors with tacho connection
- Motors with speed sensor
- Motors with integrated flushing valve
- OMT/ OMV/TMT motors with reinforced parts
- Motors can be supplied painted

The Sauer-Danfoss LSHT motors are used in the following application areas:

- Construction equipment
- Agricultural equipment
- Material handling & Lifting equipment
- Forestry equipment
- Lawn and turf equipment
- Special purpose
- Machine tools and stationary equipment
- Marine equipment

**Conversion Factors**

1 Nm	=	[8.851 lbf·in]	1 cm <sup>3</sup>	=	[0.061 in <sup>3</sup> ]
1 N	=	[0.2248 lbf]	1 l	=	[0.22 UK gal]
1 bar	=	[14.50 psi]	1 l	=	[0.264 US gal]
1 mm	=	[0.0394 in]	°F	=	[1.8 °C + 32]

**Contents and  
 Technical Literature  
 Survey**

**Survey of technical data on Sauer-Danfoss orbital motors** ..... 4

**Orbital motors, general** ..... 5

**Selection of motor type** ..... 7

    Main types ..... 7

    Motor variants ..... 9

**Selection of motorsize** ..... 13

    Build-up of the function diagram ..... 13

    Use of the function Diagram ..... 16

    Minimum speed ..... 17

Bearing dimensioning ..... 18

Hydraulic systems ..... 20

    Max. pressure on the shaft seal ..... 20

    Drain line ..... 21

    Braking ..... 22

    Brake motors ..... 25

    Installation, starting up and maintenance ..... 26

    Oil types ..... 27

    Temperature, viscosity and filtering ..... 28

**Survey of Literature  
 with Technical Data on  
 Sauer-Danfoss Orbital  
 Motors**

Detailed data on all Sauer-Danfoss motors can be found in our motor catalogue, which is divided into 4 individual subcatalogues:

- Technical data on small motors:                    OML and OMM
- Technical data on medium sized motors:            OMP, OMR, OMH and OMEW
- Technical data for medium-sized motors:            DH and DS
- Technical data on large motors:                      OMS, OMT, and OMV

The most important data on all Sauer-Danfoss orbital motors is highlighted in a general survey brochure.

For Technical informations on the individual variants, please contact the Sauer-Danfoss Sales Organisation.

**Operating Principle**

Orbital motors convert hydraulic energy (pressure, oil flow) into mechanical energy (torque and speed).

Sauer-Danfoss orbital motors are of fixed displacement high-torque design. For a given oil flow and given pressure the displacement (size of motor) determines the speed and torque. For a given displacement (size of motor) the speed is determined by the oil flow rate and the torque is determined by the pressure differential.

*Gearwheel set*

The operating principle of the motors is based on an internal gear design, consisting of a fixed external gear reaching against an internal gear through which the output torque and speed are transmitted. There are two forms of external gear: the OML, OMM, OMP and DH have plain teeth, whereas the OMR, DS, OMH, OMEW, OMS, OMT, OMV and TMT have teeth fitted with rollers.

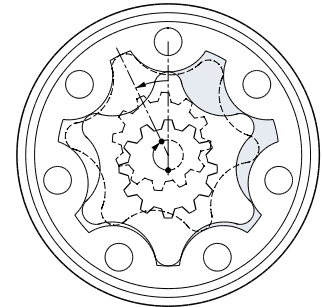

151-1028.10

*Distributor valve*

The distributor valve is driven synchronously by the internal gear through a cardan shaft ensuring that the individual chambers of the motor are filled and emptied precisely - without losses. There are two forms of distributor valve:

- *Spool valve*

OML, OMM, OMP, OMR, DH, DS and OMH motors have a spool valve: the distributor valve has been integrated with the output shaft. The cardan shaft must therefore rotate the distributor valve as well as transfer mechanical energy from the gear-wheel set to the output shaft.

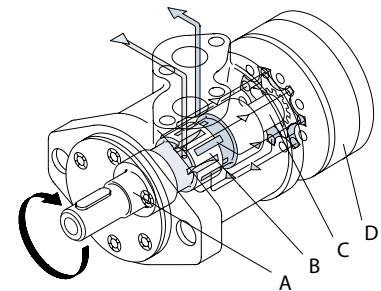

151-1052.10

- A: Output shaft
- B: Spool valve
- C: Cardan shaft
- D: Gearwheel set

- *Disc valve with valve drive*

OMS, OMT, OMV and TMT motors have a disc valve: The distributor valve has been separated from the output shaft and it is driven by a short cardan shaft [valve drive]. A balance plate counterbalances the hydraulic forces around the distributor valve.

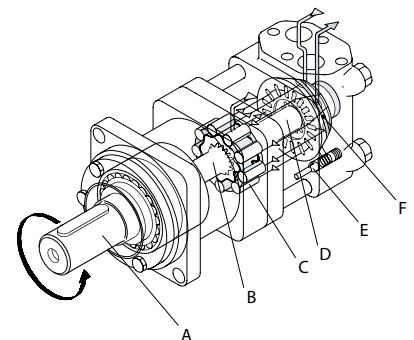

151-1053.10

- A: Output shaft
- B: Cardan shaft
- C: Gearwheel set
- D: Valve drive
- E: Check valve
- F: Disc valve

**Operating Principle**  
**(continue)**

*Disc valve on the output shaft*

- OMEW motors have a disc valve-mounted on the output shaft. The cardan shaft rotates the disc valve and transfers mechanical energy from the gearwheel to the output shaft. The hydraulic forces are equalised by the balance plate.

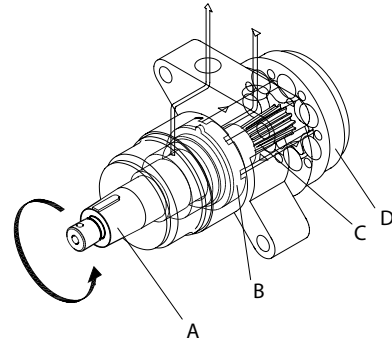

151-1808.10

A: Output shaft  
B: Disc valve

C: Cardan shaft  
D: Gearwheel set

### Selection of Motor Type

*OML, OMM, OMP, OMPW, DH*

- Rollerless gear rim
- Spool valve integrated with output shaft
- Output shaft supported in slide bearings

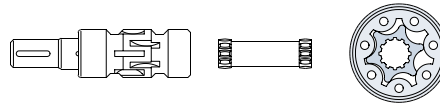

*OMPW N*

- Rollerless gear rim
- Spool valve integrated with output shaft
- Output shaft supported in needle bearings

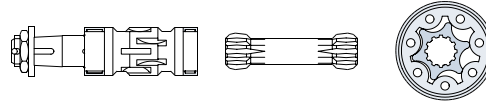

*OMR, OMH, DS*

- Gear rim with rollers
- Spool valve integrated with output shaft
- Output shaft supported in slide bearings

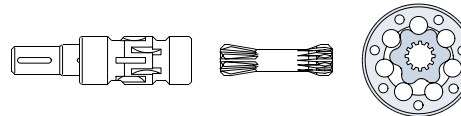

*OMRW N*

- Gear rim with rollers
- Spool valve integrated with output shaft
- Output shaft supported in needle bearings

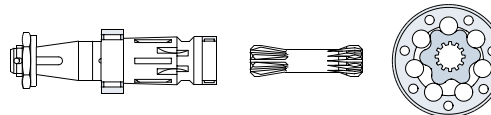

*OMEW*

- Gear rim with rollers
- Disc valve on output shaft
- Output shaft supported in needle bearings

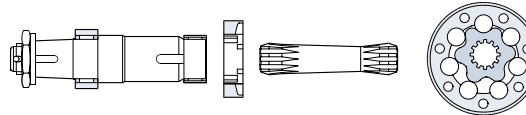

*OMS, OMT, OMV*

- Gear rim with rollers
- Disc valve with separate valve drive
- Output shaft supported in tapered roller bearings

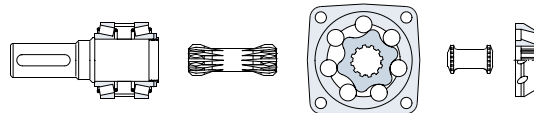

*TMT*

- Gear rim with rollers
- Disc valve with separate valve drive
- Output shaft supported in tapered roller bearings

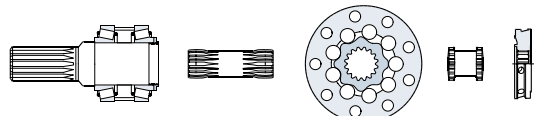

151-1374.10

### Features of main types

#### *OML, OMM, OMP, OMPW, DH*

Compact design. The rollerless gear rim makes these types suitable for long operating periods at moderate pressures, or short operating periods at high pressures.

#### *OMPW N*

Compact motor suitable for long operating periods at moderate pressures or short operating periods at high pressures. The needle bearings on the output shaft make OMPW N suitable for applications with static and dynamic radial loads.

#### *OMR, OMH, DS*

The rollers in the gear rim reduce local stress, spread the tooth load over their projected area and reduce the tangential reaction forces on the inner gear reducing friction to a minimum. This gives long operating life and better efficiency even at continuous high pressures. Gearwheel sets with rollers are recommended for operation with thin oil and for applications having continually reversing loads.

**Features of Main Types  
(continue)***OMRW N*

Because of the rollers in the gear rim OMRW N is suitable for continuous operation under demanding operating conditions: e.g. high pressures, thin oil, or frequent reversals. The needle bearings of the output shaft make OMRW N suitable for absorbing static and dynamic radial loads.

*OMEW*

OMEW motors have a disc valve mounted on the output shaft, i.e. hydraulic and mechanical losses are reduced to a minimum and the gearwheel set is fitted with rollers. OMEW is therefore ideal for continuous operation in demanding conditions. The output shaft runs in needle bearings capable of absorbing static and dynamic radial loads. OMEW motors are fitted with a high-pressure seal; therefore the drain line can be omitted.

*OMS, OMT, OMV*

OMS, OMT, and OMV are suitable for continuous operation under rough operating conditions: e.g. high pressures, thin oil, or frequent reversals. The tapered roller bearings make the motors suitable for absorbing static and dynamic radial loads. Besides the separately driven and hydraulically balanced disc valve, hydraulic and mechanical losses are reduced to a minimum. This gives the motors high efficiency - even at high pressures, and good starting characteristics.

*TMT*

The marked for hydraulic motors has developed generally increasing expectations of the motor performance, and especially of a higher pressure level. On some applications the present motor program no longer fulfils the marked demand. The TMT motors comply with these expectations providing the same good characteristics as the OMS, OMT and OMV motors.

If the application requires very smooth running at low speeds the choice of OMS, OMT, OMV or TMT is recommended.



**Motor Variants**

*Motors with corrosion resistant parts*

OMP and OMR motors are available in a version with corrosion resistant parts: OMP C and OMR C. The corrosion resistant parts are: output shaft (1), key (2), front cover (3), and front cover screws (4). The dust seal (5) is of nitrile rubber with stainless steel cap.

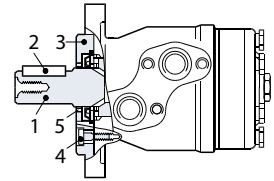

151-1373.10

*OMP/OMR with dust seal cap*

OMP and OMR motors are also available with a dust seal cap. These motors are particularly suitable for sweepers, etc. where resistance to high dust concentrations is a requirement.

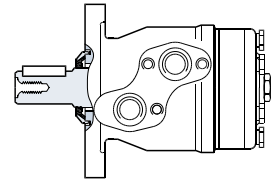

151-1893.10

*Wheel motor*

OMP, OMR, OMS, OMT and OMV motors are available in wheel motor versions. The recessed mounting flange makes it possible to fit a wheel hub or a winch drum so that the radial load acts midway between the two motor bearings. This gives the best utilisation of the bearing capacity and is a very compact solution. Type designations of wheel motors are OMPW, OMPW N, OMRW N, OMEW, OMSW, OMTW, and OMVW.

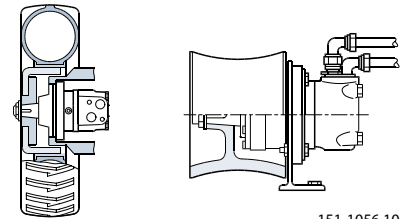

151-887.10

151-1056.10

*OMP/OMR with needle bearing*

For applications that want to use the OMP/OMR but must also consider other operating conditions such as high static radial load, frequent starts/stops and vibration on the shaft, we can offer OMP/OMR with an output shaft running in needle bearings.

Type designation: OMP N, OMR N.

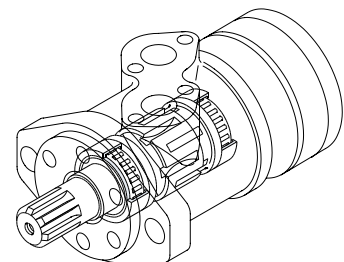

151-1464.10

**Motor Variants  
 (continue)**

*Super low leakage motor*

The OMR motor is available in a special version that keeps spool valve and output shaft apart and supports the output shaft in needle bearings. This motor is particularly suitable for applications with demands for exceptionally low leakage.

Type designation: OMR NA.

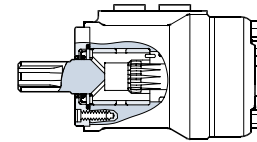

151-1624.10

*Short motors*

OMS, OMT and OMV motors are available in short versions. It can be an advantage to use a short motor for gears that already have the capacity to absorb radial and axial forces.

Type designations are OMSS, OMTS and OMVS.

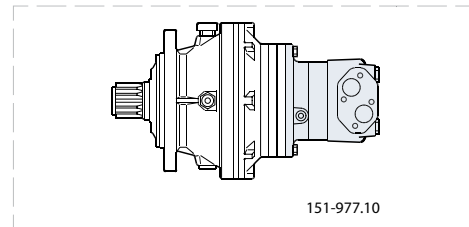

151-977.10

*Ultrashort motor*

OMS, OMT, OMV and TMT are available with ultrashort installation dimensions, i.e. without bearings and output shaft. The ultrashort design allows an optimised integration of the motor in the counterpart. Special installation conditions please contact the Sauer-Danfoss Sales Organisation.

Type designations: OMSU, OMTU, OMVU and TMTU.

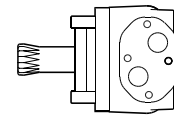

151-1691.10

*Motors with integrated positive holding brake*

OMS is available in a version with integral holding brake. This is a drum brake activated mechanically (positive brake). Type designation for OMS with integral holding brake is OMS B.

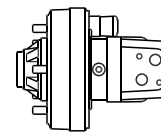

151-1188.10

*Motors with integrated negative holding brake*

OMR motors are available with integrated multi-disc brake that is released by hydraulic pressure. The brake motor can be used in closed loop or open loop systems.

Type designation: OMR F

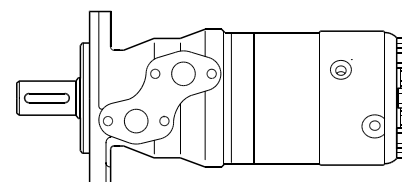

151-1797.10

**Motor Variants  
 (continue)**

*Motors with integrated negative holding brake*

OMT and TMT with integrated multi-disc brake is available in four versions: OMT FH, OMT FL, OMT FX and TMT FL. The brake is a spring activated multi-disc type that is released by a hydraulic pressure. OMT FH can work with high drop pressure [e.g. piloted from a shuttle valve in open loop systems], whereas OMT FL, OMT FX and TMT FL release the brake at low pressure [e.g. piloted from the charge pump in closed loop systems]. OMT FX are particularly well-suited for applications that require very short installation dimensions, - for example in road rollers and wheels. The design of the OMT F and TMT F motors allows the brake to be used as dynamic emergency brake as well.

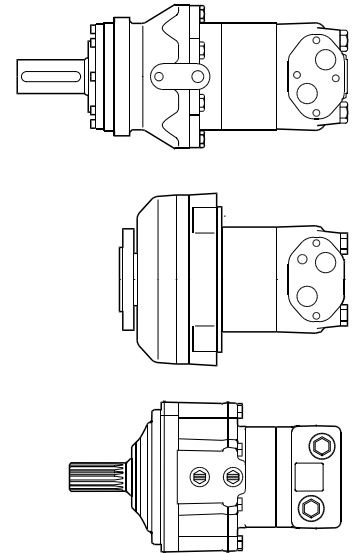

151-1425.10

*Motors with integrated flushing valve*

Without any change to their outer dimensions, OMS, OMT, OMV and TMT are available with an integrated flushing valve. The integrated flushing valve ensures continuous renewal and cooling of the oil in the closed circuit. The flushing valve is activated by the high pressure side of the motor and allows the flushing flow to pass to the drain line and the tank. Type designation: OMS V, OMT V, OMV V and TMT V .

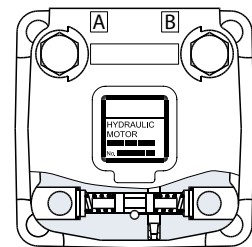

151-1627.10

*Motors with tacho connection*

OMS, OMT and OMV motors are available in a version with tacho drive shaft. With a tacho connection the speed of the motor can be registered. Type designations are OMS T, OMT T and OMV T.

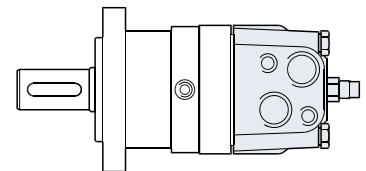

151-1372.10

**Motor Variants  
(continue)***Motors with speed sensor*

OMM, OMP, OMR, OMS, OMSW, OMT and OMV are available with integrated speed sensor. The electric output signal is a standardized voltage signal that may for example be used with Sauer-Danfoss' electronic module type EHSC to control the speed of the motor. The speed is registered by an inductive sensor. Signal processing and amplification are integrated in the housing of the sensor. Type designation: OM - EM.

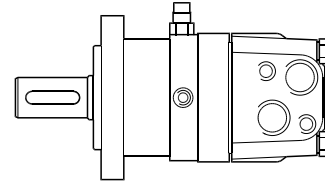

151-1569.10

*OMT N motor*

OMT is available in a short version with high bearing capacity. The motor is very suitable for the propulsion of road rollers and similar equipment. Type designation: OMT N

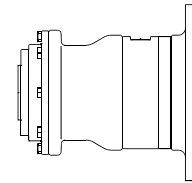

151-1796.10

**Selection of Motor Size**

When a certain motor type has been selected in accordance with the requirements of the individual application, the size of the motor is determined according to the torque and speed required for the application. For this purpose use the bar chart on the first pages of the subcatalogues and the function diagram for the individual motor.

**Build-up of the Function Diagram**

The function diagram for a hydraulic motor shows the relation between operating torque  $M$  (vertical axis) and speed  $n$  (horizontal axis) at different pressure drops  $\Delta p$  and oil flows  $Q$ . The curves for constant pressure drop and constant oil flow form a network superimposed on the coordinate system grid. The curves for constant power output  $N$  (hyperbolas) and constant total efficiency  $\eta_t$  are also plotted. The latter curves have a ring form, as on mussel shells. For this reason function diagrams are often called shell diagrams.

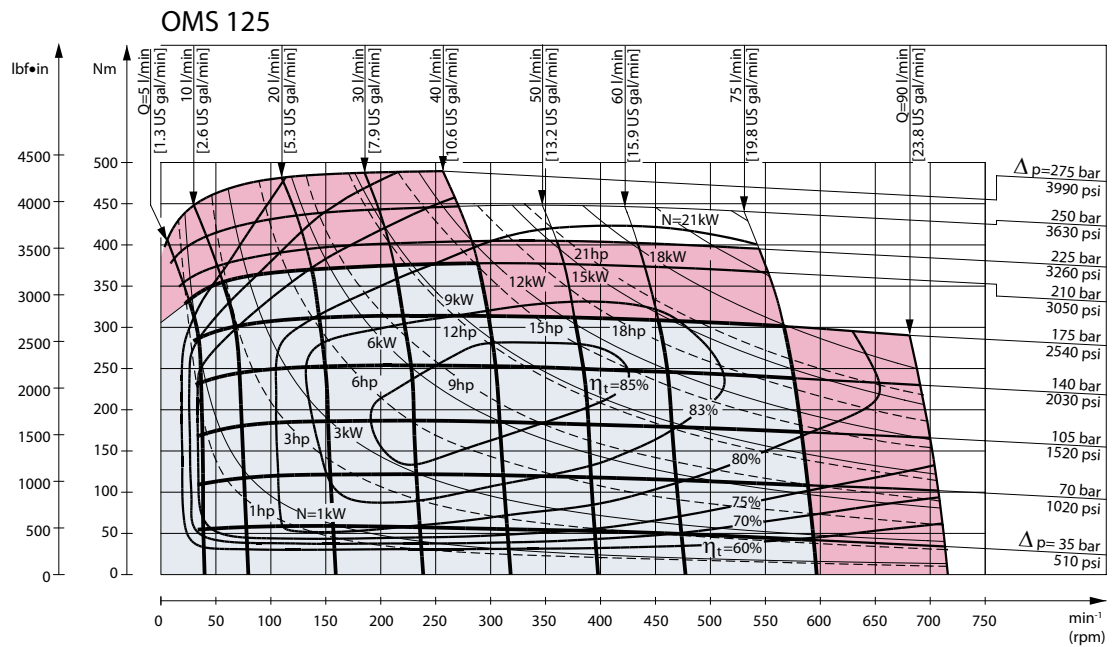

151-903.10

**Continuous operation/intermittent operation/peak load**

The function diagrams are divided up into a dark area A and two light areas B.

The dark area A represents the continuous range of the motor. Within this range the motor is able to run continuously with optimum efficiency and operating life.

The two light areas B represent the intermittent range of the motor. It is advantageous to make use of the intermittent range when the motor works with varying loads, but also to allow for braking torques when reversing direction.

It is permissible to subject the motor to intermittent speed or intermittent pressure drop for max. 10% of every minute. The motor should not be subjected to intermitend speed and intermitend pressure drop at the same time.

**Build-up of the  
 Function Diagram  
 (continue)**

The upper limits for intermittent pressure drop and torque must not be exceeded for more than 1% of every minute (peak load). The max. peak load value is stated in the technical data for each type of motor. High pressure peaks occur, for example, when a pressure relief valve opens or a directional valve is opened or closed. Pressure relief valves and dual shock valves should be set so that pressure peaks do not exceed the max. peak values. In systems with large pressure oscillations the pressure and torque peaks should be measured with electronic equipment.

To give problem-free operation the motor size should be selected using the permissible continuous and intermittent values while making sure that pressure peaks do not exceed the max. peak values.

*Efficiency*

The total efficiency  $\eta_t$  is the product of the volumetric efficiency ( $\eta_v$ ) and the hydraulic-mechanical efficiency ( $\eta_{hm}$ ). Thus  $\eta_t = \eta_v \times \eta_{hm}$ .

*Volumetric efficiency*

The volumetric efficiency is an expression for the proportion of the applied quantity of oil [as a percentage] that is converted to output shaft revolutions (speed). The remaining quantity of oil (leakage) is led across clearances and sealing surfaces to act as a lubricant/coolant.

When the load (pressure drop) increases, leakage also increases.

The quantity of oil supplied to the gearwheel set thus diminishes, and the number of revolution (speed) falls.

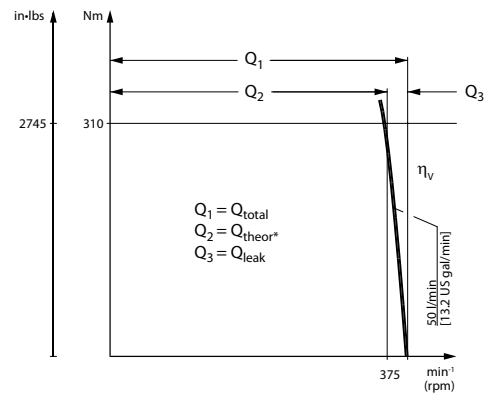

The slope of the Q-curve expresses the magnitude of the efficiency

*Example*

An OMS 125 is to drive a shaft at a speed of  $375 \text{ min}^{-1}$  (rpm) with an applied torque of 310 Nm [2745 lbf·in].

If the volumetric efficiency was 100% the oil quantity would be the geometric displacement times the number of revolutions.

Theoretical supplied oil quantity:

<b>Metric</b>	<b>US units</b>
$Q_{\text{theor}} = \frac{\text{Displ. (cm}^3\text{)} \cdot \text{speed (min}^{-1}\text{)}}{1000} \quad (\text{l/min})$	$Q_{\text{theor}} = \frac{\text{Displ. [in}^3\text{]} \cdot \text{speed [rpm]}}{231} \quad [\text{US gal/min}]$
$= \frac{125.7 \cdot 375}{1000} \sim 47 \text{ l/min}$	$= \frac{7.67 \cdot 375}{231} \sim 12.45 \text{ US gal/min}$

**Build-up of the  
 Function Diagram  
 (continue)**

However, the actual supplied oil quantity is 50 l/min [13.2 US gal]. The volumetric efficiency can be calculated as follows:

$$\eta_v = \frac{47 \cdot 100}{50} \sim 94\%$$

$$\eta_v = \frac{12.45 \cdot 100}{13.2} \sim 94\%$$

**Hydraulic mechanical efficiency**

The hydraulic mechanical efficiency is an expression for the proportion of applied pressure (as a percentage) that is converted to output shaft torque. The remaining pressure is loss; either mechanical loss at low speeds or hydraulic loss at high speeds, as can be seen on the torque graph (pressure-drop curve). Mechanical loss is greatest at motor start-up because a film of lubricant has not yet been built up on moving parts. After a few revolutions the film is established and friction is reduced (the curve steepens). Hydraulic loss is greatest at high speeds because of the high pressure losses in ports and oil channels when oil flow is high. Therefore the pressure drop across the gearwheel set becomes less and the motor yields less torque.

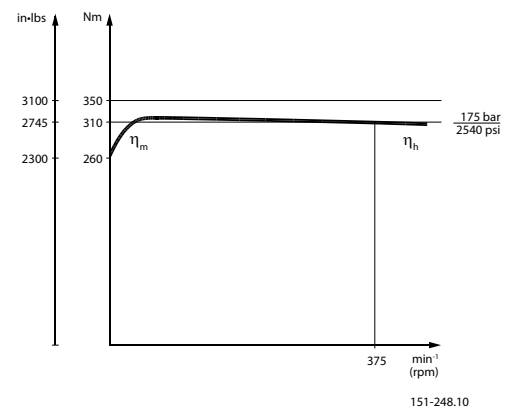

OMS 125 has a minimum starting torque of 260 Nm [2300 lbf·in] at a pressure drop of 175 bar [2540 psi], as given in the OMS technical data table. When the lubricant film is established, the motor yields 310 daNm [2745 lbf·in] with the same pressure drop. On the function diagram the pressure drop curve does not intersect the torque axis, but min. starting torque at max. continuous and max. intermittent pressure drop is given in the technical data for each motor type.

**Example:**

To calculate the hydraulic-mechanical efficiency  $\eta_{hm}$ , it is necessary to first read off (measure) the motor torque  $T_{mot\ eff}$  for a given oil flow and given pressure drop. The diagram on page 13 shows that an OMS 125 gives a torque of 310 Nm [2745 lbf·in] for a pressure drop of 175 bar [2540 psi] and an oil flow of 50 l/min [13.20 US gal/min].

The theoretical motor torque for the same pressure drop can be calculated as follows:

$$T_{theo} = \frac{\text{Displ. (cm}^3) \cdot \text{pressure drop (bar)}}{62.8} \text{ (Nm)}$$

$$T_{theo} = \frac{\text{Displ. (in}^3) \cdot \text{pressure drop (psi)}}{6.28} \text{ [lbf·in]}$$

**Build-up of the  
 Function Diagram  
 (continue)**

Metric	US units
$T_{\text{theo}} = \frac{125.7 \cdot 175}{62.8} \sim 350 \text{ Nm}$	$T_{\text{theo}} = \frac{7.67 \cdot 2540}{6.28} \sim 3102 \text{ lbf-in}$

Dividing the read-off (measured) torque by the theoretical torque gives the hydraulic-mechanical efficiency:

$\eta_{\text{hm}} = \frac{310 \cdot 100}{350} \sim 89\%$	$\eta_{\text{hm}} = \frac{2745 \cdot 100}{3102} \sim 89\%$
--	--

*Total efficiency*

It is now possible to calculate the total efficiency of OMS 125 at  $\Delta p = 175 \text{ bar}$  [2540 psi] and  $Q = 50 \text{ l/min}$  [13.2 US gal/min]:

$$\eta_t = \frac{\eta_v \cdot \eta_{\text{hm}}}{100} = \frac{94 \cdot 89}{100} \sim 84\%$$

With an acceptable degree of accuracy the same total efficiency can be read from the function diagram efficiency graphs, page 13.

**Use of the Function  
 Diagram**

The function diagram is for use when the right Sauer-Danfoss motor (and pumps, etc.) has to be selected for an application.

For example, a motor is required with an output:

Max. cont. speed:  $425 \text{ min}^{-1}$  (rpm)

Max. cont. torque: 260 Nm [2300 lbf·in]

In the subcatalogues and in the survey brochure the maximum speed and torque of the different motors can be compared. The smallest motor able to meet the requirements is to be found in the OMR or OMS series. But only OMR 125, OMS 125, and OMS 160 can meet both the required speed and torque.

The function diagrams for OMR 125, OMS 125 and OMS 160 can now be used. Find the operating point concerned, i.e. the torque on the vertical axis  $T = 260 \text{ Nm}$  [2300 lbf·in], speed on the horizontal axis  $n = 425 \text{ min}^{-1}$  (rpm).

The position of the operating point (T,n) in relation to the curves for constant pressure drop  $\Delta p$ , constant oil flow Q, and constant total efficiency  $\eta_t$ , gives the following associated values:

Motor	Pressure ( $\Delta p$ )		Oil flow (Q)		Efficiency $\eta_t$ (%)
	bar	[psi]	l/min	[US gal/min]	
OMR 125	158	2292	59	15.59	73
OMS 125	145	2103	56	14.79	83
OMS 160	119	1726	70	18.49	81



**Build-up of the  
Function Diagram  
(continue)**

Which is now the most important factor in an overall economic and technical assessment: the initial price of the hydraulic system, its efficiency or its operating life?

If the answer is the price of the motor, the choice is an OMR 125. The choice between OMR 125 and OMRW 125 N is made according to the required bearing load.

If the efficiency of the motor is all-important, the choice is an OMS 125. The slightly higher initial price of OMS 125 compared with OMR 125 will often be compensated for by a better system design with associated savings in running costs and reduced heat generation. As an additional advantage OMS 125 also requires the least oil flow.

When it comes to operating life being the most important factor, the choice is an OMS 160. It has the least working pressure and thereby gives the longest system operating life.

When the size of motor has been decided, the capacity of the pump can be determined. If, for example, the choice had been an OMS160, the pump would have had to be able to deliver 70 l/min [18.49 US gal/min] at 119 bar [1726 psi].

If a hydraulic motor is to be installed in an existing system with a given pump, then the choice of motor is largely predetermined.

**Minimum Speed**

At very low speeds, the motors may run less smoothly. This is why a min. speed is stated for each type of motor. In borderline cases a motor of the desired type should be tested under the required operating conditions in the system concerned before finally selecting the motor size and type.

To obtain smooth running at very low speed the motor leakage must be constant. Therefore it is recommended that a motor with disc valve (OMS, OMT, OMV or TMT) be chosen, but avoid choosing motors with the smaller displacements. The best results are achieved with a constant load, a return pressure of 3-5 bar [45-70 psi] and an oil viscosity of min. 35 mm<sup>2</sup>/s [164 SUS].

**Shaft Load and  
 Bearing Life Time**

In many applications the hydraulic motors must absorb both

- external radial and axial forces acting directly on the output shaft of the motor (e.g. from the weight of a vehicle)
- radial forces produced by torque transfer from gearwheels, chainwheels, V-belts or winch drums.

For such applications hydraulic motors with built-in rolling bearings are particularly suitable. Two different types of bearing are used in Sauer-Danfoss hydraulic motors:

- 1) Needle bearings in OMPW N, OMRW N and OMEW.  
 The needle bearings are capable of absorbing large radial forces. As the motors have separate axial bearings, the operating life of the needle bearings is not affected by the size of the axial load.
- 2) Tapered roller bearings in OMS, OMSW, OMT, OMTW, OMV, OMVW and TMT  
 The tapered roller bearings can absorb large radial and axial forces.

The largest possible bearing capacity for the individual motor type is obtained by using OMPW N, OMRW N, OMEW, OMSW, OMTW, or OMVW because the recessed mounting flange makes it possible to fit for example wheel hubs and winch drums so that the radial load is applied centrally to the two bearings.

*Motor with needle bearings*

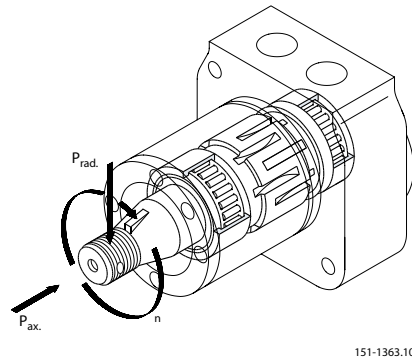

*Motor with tapered roller bearings*

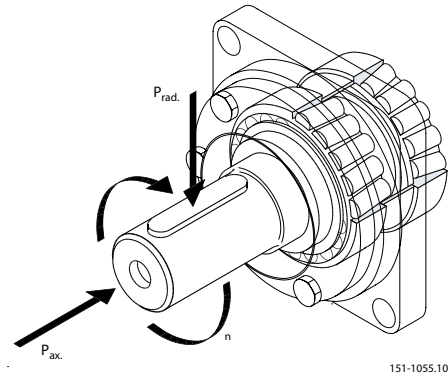

**Relationship between  
 Bearing Life Time and  
 Speed**

It is a general rule that life time and speed are inversely proportional: life is doubled when speed is halved. So life can easily be calculated for other speeds than those given in the sections on shaft load in the individual subcatalogues.

The relation is expressed by the formula:

$$L_{new} = L_{ref} \times \frac{n_{ref}}{n_{new}}$$

where  $L_{new}$  is the life time at speed  $n_{new}$  and  $L_{ref}$  and  $n_{ref}$  are the data for the given motor type found in the subcatalogue.

**Relationship between Shaft Load and Bearing Life Time**

Lower shaft loads result in longer life time of the bearings. The exact relationship is shown by the following formula:

$$\frac{L_{new}}{L_{ref}} = \left( \frac{P_{ref}}{P_{new}} \right)^{3.3}$$

$L_{new}$  is the bearing life at a shaft load of  $P_{new}$  and  $L_{ref}$  and  $n_{ref}$  are data from the subcatalogue.

Note:

- The formula applies to OMPW N, OMEW and OMRW N regardless of the relation between the axial and radial loads.
- With the other motors the formula only applies if there is a constant relation between the axial and radial loads.

**Relationship between Permissible Shaft Load and Speed**

In certain applications the motor must run at low speeds while the bearings must absorb high loads. This is the case for example when the motors are vehicle support elements. In such cases the following relationship between speed and bearing load (with unchanged bearing life time) must be taken into account:

$$\frac{P_{new}}{P_{ref}} = \sqrt[3.3]{\frac{n_{ref}}{n_{new}}}$$

$P_{new}$  is the shaft load at  $n_{new}$ ,  $P_{ref}$  and  $n_{ref}$  are data from the subcatalogue.

For  $n_{ref} = 200 \text{ min}^{-1}$  [rpm] we have the following table for

$$\frac{P_{new}}{P_{ref}} :$$

$\frac{n_{new}}{\text{min}^{-1}(\text{rpm})}$	25	50	100	200	300	400	500	600	700
$\frac{P_{new}}{P_{ref}}$	1.88	1.52	1.23	1.00	0.88	0.81	0.75	0.72	0.68

**Maximum Radial Shaft Load**

The calculations above are solely for bearing life time and load capacity. But there is also a limit to how much load the other parts of the motor (bearing housing, mounting flange and output shaft) can carry. For this reason the maximum shaft load is limited to avoid the risk of mechanical breakdown.

The maximum shaft load is shown in the shaft load diagrams for OMPW N, OMRW N, OMEW, OMS, OMT, OMV and TMT motors.

Please contact the Sauer-Danfoss sales organisation for hydraulics if motors are to be subjected to shaft loads higher than the maximum, or where there are particularly high dynamic effects (shock factor > 3).

**Max. Pressure on the Shaft Seal**

Sauer-Danfoss hydraulic motors can be supplied fitted with one of three different shaft seals:

*Standard shaft seal (NBR)*

The standard shaft seal in Sauer-Danfoss hydraulic motors has a long operating life and even under extreme conditions retains its sealing capability. With optimal lip design, the shaft seal withstands both high pressures and high speeds.

*High-pressure shaft seal (NBR)*

The high-pressure shaft seal (HPS) is a development of our standard shaft seal and the integrated backing ring makes an external drain line superfluous in most operating conditions.

*Viton shaft seal (FPM)*

If a synthetic fluid is to be used in our hydraulic motors we recommend a Viton shaft seal.

*Characteristics of sealing materials*

Material	Temperature °C [°F]	Remarks
NBR	-30 to + 100 [-22 to 212]	Swells up on contact with most synthetic fluids Can be used with Emulsions and Mineral oils
FPM	-30 to + 150 [-22 to 302]	Ideal for mineral oil, synthetic fluids and emulsions

All Sauer-Danfoss motors, except the OMEW, are 3-chamber type of motors, i.e. this type of motor isolates the high pressure from the case, which allows the use of an external drain when return line pressure is excessive. These motors are offered with the following option:

*Motors with check valve*

The check valve means that the pressure on the shaft seal never exceeds the pressure in the return line. If the motor contains check valves and there is no drain line, the motor return pressure must always be less than or equal to the maximum permissible pressure on the shaft seal graph in the subcatalogue.

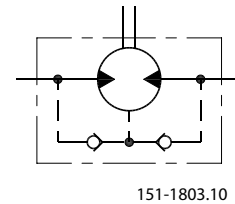

*Motors with drain line*

The drain line relieves the pressure on the shaft seal to tank. That is to say, the tank pressure must be less than or equal to the max. permissible pressure on the shaft seal graph in the subcatalogue.

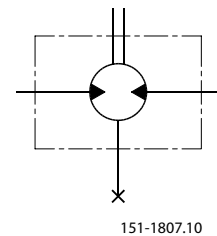

*Motors without check valve and drain line*

The pressure on the shaft seal is equal to the average of the inlet pressure and return pressure:

$$P_{\text{seal}} = \frac{P_{\text{inlet}} + P_{\text{return}}}{2}$$

$P_{\text{seal}}$  must be less than or equal to the max. permissible pressure on the shaft seal graph in the subcatalogue.

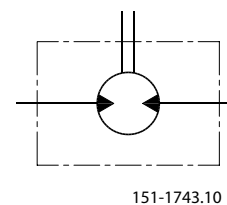

**Max. Pressure on the Shaft Seal (continue)**

The OMEW is a 2-chamber rotor with a high-pressure shaft seal. The OMEW motor is available in CW version (clockwise rotation) and CCW version (counter clockwise rotation).

Depending on the motor rotation the pressure on the shaft seals is as follows:

*OMEW with high pressure shaft seal*

CW version (clockwise rotation)

- 1) By clockwise rotation: The shaft seal pressure equals the return pressure.
- 2) By counter clockwise rotation: The shaft seal pressure equals the input pressure.

*CCW version (counter clockwise rotation)*

- 1) By counter clockwise rotation: The shaft seal pressure equals the return pressure.
- 2) By clockwise rotation: The shaft seal pressure equals the input pressure.

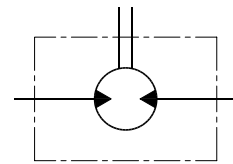

151-1743.10

*Short/ultra-short motors*

For these motors it is the values of the pressure on the shaft seal in connected component (e.g. a gear) that applies.

**Drain Line**

*Application*

The drain line relieves pressure on the shaft seal to tank. The following main rules apply to drain lines fitted to Sauer-Danfoss hydraulic motors:

- We recommend a drain line when the maximum pressure on the shaft seal is exceeded, i.e. the life of the shaft seal can otherwise be significantly reduced.
- We always recommend a drain line when
  - a short motor is built together with a gear.
  - the motor is used in hydrostatic transmissions that do not have a separate flushing valve.

*Oil flow in the drain line*

When the size of the supply pump in a closed hydraulic circuit is to be calculated, it is necessary to know the maximum oil flow in the drain line. The maximum oil flow in the drain line for Sauer-Danfoss hydraulic motors is given in the technical data in the catalogue for each motor type.

## Braking

Sauer-Danfoss hydraulic motors are often used to brake a load. Here the motors operate as pumps that convert the kinetic energy of the load (mass, speed) to hydraulic energy (oil flow, pressure). Examples of these types of applications are:

- Crane winches on vehicles
- Net winches on fishing vessels
- Top jib slewing on cranes and excavators
- Hydrostatic transmissions

The speed at which the load is braked is determined by the motor braking torque and the opening pressure of the dual shock valve.

### Braking torque

With a motor, the hydraulic-mechanical efficiency means that the effective torque is lower than the theoretical torque.

$$T_{\text{motor eff}} = T_{\text{theor}} \times \eta_{\text{hm}} \quad (1)$$

With a pump, the hydraulic-mechanical efficiency means that the effective torque that must be applied to the pump to create a given pressure drop is greater than the theoretical pressure drop.

$$T_{\text{pump eff}} = \frac{T_{\text{theor}}}{\eta_{\text{hm}}} \quad (2)$$

When a hydraulic motor is used as a pump (for braking) the ratio between braking torque and effective motor output for a given pressure drop is as follows:

$$T_{\text{brake}} = \frac{T_{\text{theor}}}{\eta_{\text{hm}}} \quad (\text{see 2}) \quad \text{where}$$

$$T_{\text{theor}} = \frac{T_{\text{motor eff}}}{\eta_{\text{hm}}} \quad (\text{see 1})$$

$$T_{\text{brake}} = \frac{T_{\text{motor eff}}}{(\eta_{\text{hm}})^2}$$

We recommend the use of the following braking torques for Sauer-Danfoss hydraulic motors:

- OMS, OMT, OMV, TMT :  $T_{\text{brake}} \sim 1.2 \cdot T_{\text{motor eff}}$
- Other motors :  $T_{\text{brake}} \sim 1.3 \cdot T_{\text{motor eff}}$

$T_{\text{motor eff}}$  can be read from the function diagram for the individual motor sizes. The braking torque must not be greater than the maximum motor operating torque. The maximum torque is given in the technical data for each motor type.

### Opening pressure for the dual shock valve

The braking torque can be regulated by setting the opening pressure of the dual shock valve. The opening pressure should be set at max. oil flow, in that a 20-30% increase in opening pressure can be expected when the oil flow is changed from minimum to maximum.

To avoid excessive pressure peaks, the dual shock valve should be rapid acting and be installed as close to the hydraulic motor as possible.

**Braking  
 (continue)**

*Replenishment*

When Sauer-Danfoss hydraulic motors are used to brake a load, effective replenishment is necessary. Inadequate replenishment can give rise to:

- cavitation in the gearwheel set
- insufficient braking capacity

There must therefore be positive charge pressure in the motor "suction" port. The charge pressure ( $p_s$ ) must therefore be greater than the pressure drop in the motor oil channels feeding the gearwheel set.

The pressure drop in the oil channels depends on the motor type, oil flow and oil viscosity. The pressure drop graphs for each motor type are given in the respective catalogues. The supply pressure should constitute half the pressure drop ( $p_d$ ) given on the graph:

$$p_s = \frac{p_d}{2}$$

The charge pressure is always measured at the motor "suction" port.

In closed circuits the supply pressure will always be positive when the system is fitted with a charge pump ( $p_s \sim 10\text{-}15 \text{ bar [145-217 psi]}$ ).

In open systems where the hydraulic motor drives a load with high inertia, it is necessary to establish replenishment as shown in fig. 1.

The opening pressure of the check valve must be greater than the sum of the charge pressure ( $p_s$ ) and the pressure drop between check valve and motor "suction" port.

Fig. 1

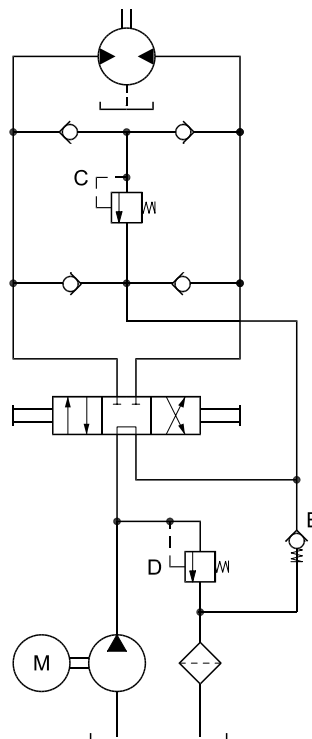

- C: Shock valve
- D: Pressure relief valve
- E: Spring-loaded check valve

151-122.10

**Braking  
(continue)**

Special conditions apply to open circuits where the hydraulic motor drives a load with high inertia. When the directional valve changes from I to II, the oil flow from pump to motor is shut off. Load inertia will continue to drive the pump and for the same reasons as above a check valve should be installed to ensure replenishment, otherwise oil will be emptied from the motor see fig. 2.

Fig. 2

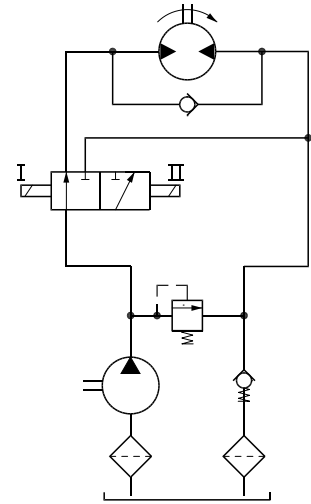

151-1142.10

**Seeping**

To prevent the load from moving during long periods, two precautions must be taken:

1. If the motor has a drain line it is necessary to ensure replenishment, otherwise oil will be gradually emptied from the gearwheel set and the load will fall freely. The best method is shown in fig. 1.
2. A orbital motor cannot retain a load in a given position without movement. Internal leakage [seeping] in the motor will result in the load moving. Therefore, with hydrostatic transmissions, with crane slewing and with winches and hanging loads, Sauer-Danfoss motors with integral holding brakes should be used. Alternatively, the drive shaft should be equipped with an external holding brake see fig. 3.

Fig. 3

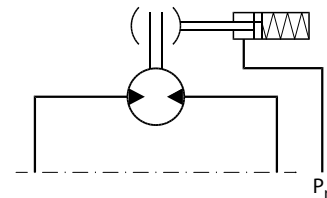

151-1143.10

External holding brake



**Sauer-Danfoss Brake Motors**

Sauer-Danfoss OMR, OMS, OMT and TMT motors are available with integrated brake:

- OMS B with drum brake activated by a mechanical operating lever.
- OMR F, OMT FX, OMT FL, TMT FL and OMT FH with spring-activated multi-disc brake released by hydraulic pressure.

**OMS B**

OMS B has a built-in mechanically activated drum brake. The motor can be braked by operating the brake lever. The brake function is therefore not an integrated part of the hydraulic system.

**OMR F, OMT FX, OMT FL and TMT FL**

These motors are suitable for hydrostatic transmissions and other closed circuits. - the supply charge pump pressure is sufficient to release the brake. The directional valve (M) can be coupled to the vehicle controls so that the brake pressure is automatically released to tank when the vehicle stops.

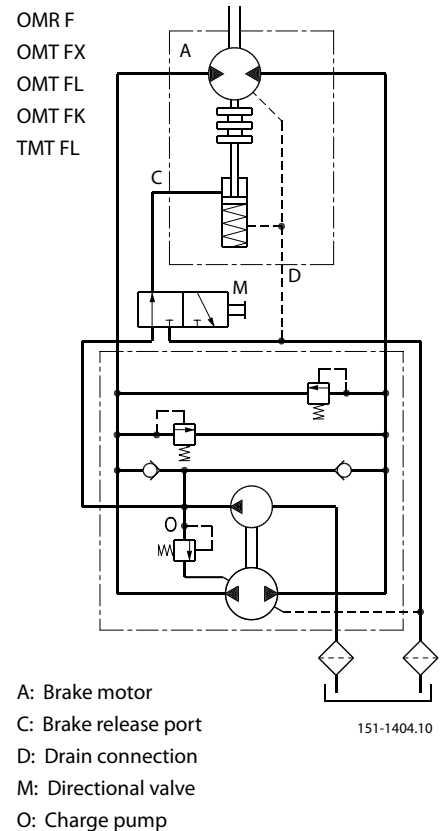

**OMR F and OMT FH**

These motors are designed for open circuits and withstands max. system pressure in the brake release line, even when the brake is released at low pressure. Brake release can be controlled by connecting the release port to the pump line.

In addition, either a changeover valve can be installed to give automatic brake release or a directional valve to control brake release.

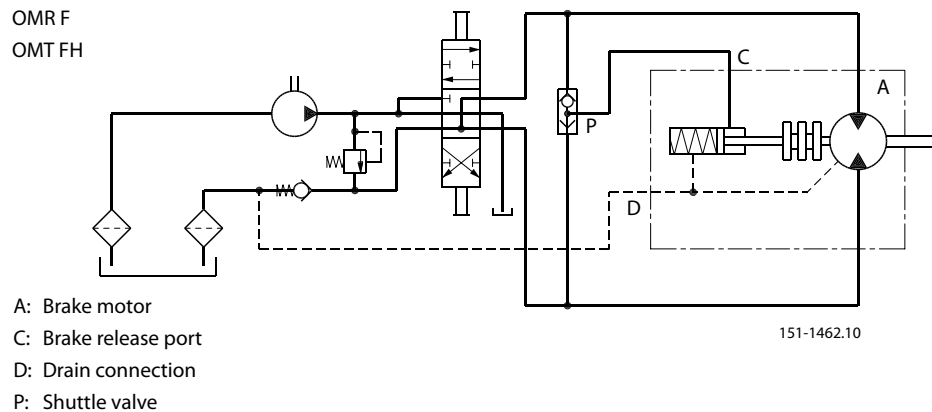

**Brake motors must always have a drain line**

**Installation,  
Starting Up and  
Maintenance**

*Design in brief*

- To ensure optimum operation all hydraulic components must be installed in accordance with their individual instructions.
- The pump line must contain a pressure gauge connection.
- To ensure correct joint contact and minimise material stress, all mounting flanges must be plane. Hydraulic lines must be installed correctly to avoid air pockets inside them.

*Combination in brief*

- Hydraulic components must be installed in accordance with their individual instructions.
- To avoid contamination, plastic plugs in connection ports must not be removed until just before connections are made.
- There must be full contact between motor mounting flange and connecting part.
- Avoid pressing the motor into place by tightening the fixing bolts.
- Avoid unsuitable seal materials, e.g. twine, teflon, etc., on threaded unions. Use only the seals supplied, such as O-rings, steel washers, etc.
- When tightening unions, never use more torque than the max. values given in instructions.
- Check to make sure the purity of the oil is better than 20/16 (ISO 4406) and always use a filter when replenishing the system.

*Starting up and running in the hydraulic system*

- Pour the oil through a fine-mesh filter and fill up the tank to the top level mark.
- Start the drive motor and allow it to run at its lowest speed, if possible. If the motor has bleed screws, allow them to remain open until the oil no longer foams.
- Check to make sure that all components are correctly connected (and that the pump runs in the correct direction, etc.).
- If a load-sensing system is involved, make sure there is no air in the signal lines.

*Signs of air in the hydraulic system*

- Foam in the tank
- Jerky movements of motor and cylinder
- Noise

*If there is air in the system*

- Replenish the oil.
- Connect the system to a separate tank with filter (filter mesh max. 10 µm). The tank capacity must be twice the max. oil flow. Allow the system to run without load [no pressure] for around 30 minutes.
- Do not load the system until it has been completely bled and is clean.
- Check for system leakage and make sure it operates satisfactory.
- Replace the oil filter and, if necessary, replenish the oil.

*During operation*

- Do not subject the motor to pressure, pressure drop or speeds exceeding the maximum values stated in the appropriate catalogues.
- Filter the oil to maintain the grade of contamination at 20/16 (ISO 4406) or better.

**Installation,  
Starting Up and  
Maintenance  
(continue)**

*Maintenance*

- With hydraulic systems the main criterion for reliability and operating life is very thorough maintenance.
- Replenish and change the oil, the oil and air filters as stated in the respective instructions.
- Regularly check the condition of the oil, system leakage and the oil level.

**Oil Types**

In a hydraulic system the most important task of the oil is to transfer energy. At the same time the oil must lubricate moving parts in hydraulic components, protect them from corrosion, and conduct dirt particles and heat out of the system. To ensure that the hydraulic components operate without problems and have a long operating life it is therefore vital to select the correct oil type with the necessary additives.

*Mineral oils*

For systems containing Sauer-Danfoss hydraulic motors, we recommend mineral hydraulic oil with anti-wear additives, type HLP [DIN 51524] or HM (ISO 6743/4). Mineral oils without anti-wear additives or engine oils can also be used, provided operating conditions are suitable.

If oil types that have not been classified are being considered, please contact the Sauer-Danfoss Sales Organisation.

*Non-flammable or biodegradable fluids*

Danfoss hydraulic motors can also be used in systems with non-flammable or biodegradable fluids. However, the function and life of the motor will depend on the type and condition of the fluid used. To achieve satisfactory operation and life it is therefore necessary to match the operating conditions to the properties of the fluid used.

Before using non-flammable or biodegradable fluids we recommend contact with the Sauer-Danfoss Sales Organisation.

**Temperature and  
 Viscosity**

Ambient temperature should lie between -30°C [-22 °F] and +90°C [+210°F] to ensure that the shaft seal retains its sealing capacity.

Oil temperature should lie between +30°C [+85°F] and +60°C [+140°F] during normal operation. Oil life is greatly reduced if its temperature exceeds +60°C [+140°F]. As a general rule, oil life is halved for each 8°C [15°F] its temperature exceeds 60°C [+140°F].

*Viscosity*

The viscosity of the oil should lie between 20 mm<sup>2</sup>/s and 75 mm<sup>2</sup>/s [100 and 370 SUS] when the operating temperature of the system has become stabilised. We recommend the use of an oil type having a viscosity of 35 mm<sup>2</sup>/s [165 SUS] at the actual operating temperature.

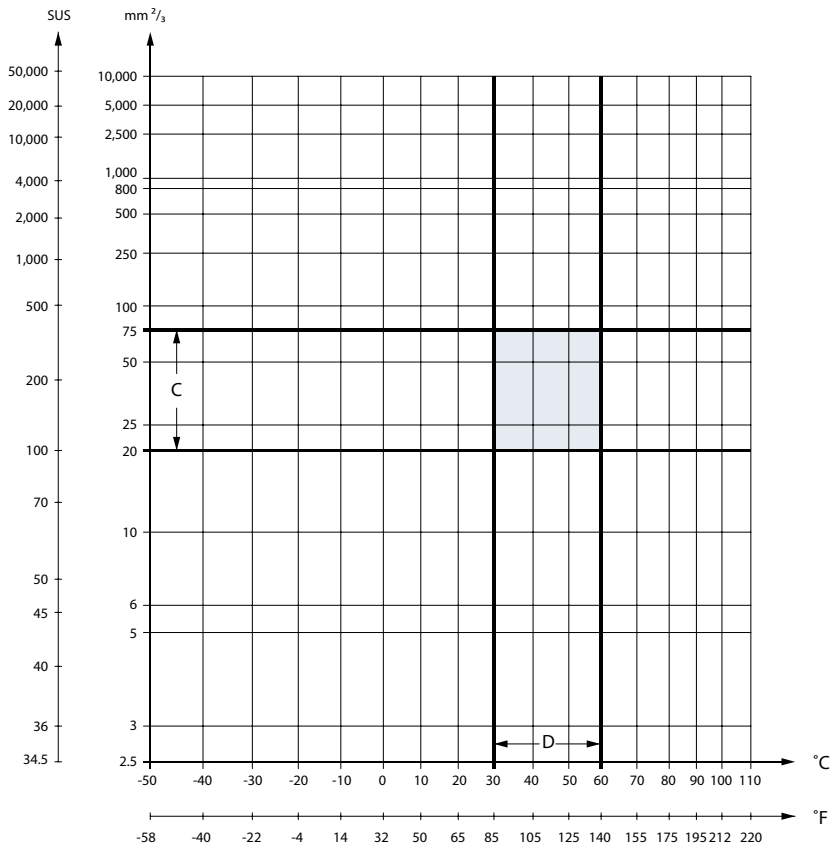

C: Recommended viscosity range  
 D: Recommended temperature range

151-1321.10

**Filtering**

It is necessary to keep the level of oil contamination at an acceptable level to ensure problem-free operation. The recommended maximum level of contamination in systems with Sauer-Danfoss hydraulic motors is 20/16 (see ISO 4406\*). In our experience the 20/16 contamination level can be met by using a return filter finer than 40 µm absolute or 25 µm nominal. In very dirty environments, in complex systems, and in closed circuits, the recommended filtration level is 20 µm absolute or 10 µm nominal.

(In systems with quick release couplings a pressure filter having a fineness of 40 µm absolute should be inserted just ahead of the motor).



General, Orbital Motors  
Technical Information  
Notes

Notes



General, Orbital Motors  
Technical Information  
Notes

Notes



General, Orbital Motors  
Technical Information  
Notes

Notes



#### Products we offer:

- Bent Axis Motors
- Closed Circuit Axial Piston Pumps and Motors
- Displays
- Electrohydraulic Power Steering
- Electrohydraulics
- Hydraulic Power Steering
- Integrated Systems
- Joysticks and Control Handles
- Microcontrollers and Software
- Open Circuit Axial Piston Pumps
- Orbital Motors
- PLUS+1™ GUIDE
- Proportional Valves
- Sensors
- Steering
- Transit Mixer Drives

#### Members of the Sauer-Danfoss Group:

##### Comatrol

[www.comatrol.com](http://www.comatrol.com)

##### Schwarz Müller-Inverter

[www.schwarzmueller-inverter.com](http://www.schwarzmueller-inverter.com)

##### Turolla

[www.turollaocg.com](http://www.turollaocg.com)

##### Valmova

[www.valmova.com](http://www.valmova.com)

##### Hydro-Gear

[www.hydro-gear.com](http://www.hydro-gear.com)

##### Sauer-Danfoss-Daikin

[www.sauer-danfoss-daikin.com](http://www.sauer-danfoss-daikin.com)

**Sauer-Danfoss** is a global manufacturer and supplier of high-quality hydraulic and electronic components. We specialize in providing state-of-the-art technology and solutions that excel in the harsh operating conditions of the mobile off-highway market. Building on our extensive applications expertise, we work closely with our customers to ensure exceptional performance for a broad range of off-highway vehicles.

We help OEMs around the world speed up system development, reduce costs and bring vehicles to market faster.  
Sauer-Danfoss – Your Strongest Partner in Mobile Hydraulics.

**Go to [www.sauer-danfoss.com](http://www.sauer-danfoss.com) for further product information.**

Wherever off-highway vehicles are at work, so is Sauer-Danfoss.

We offer expert worldwide support for our customers, ensuring the best possible solutions for outstanding performance. And with an extensive network of Global Service Partners, we also provide comprehensive global service for all of our components.

Please contact the Sauer-Danfoss representative nearest you.

Local address:

Sauer-Danfoss (US) Company  
2800 East 13th Street  
Ames, IA 50010, USA  
Phone: +1 515 239 6000  
Fax: +1 515 239 6618

Sauer-Danfoss ApS  
DK-6430 Nordborg, Denmark  
Phone: +45 7488 4444  
Fax: +45 7488 4400

Sauer-Danfoss GmbH & Co. OHG  
Postfach 2460, D-24531 Neumünster  
Krokamp 35, D-24539 Neumünster, Germany  
Phone: +49 4321 871 0  
Fax: +49 4321 871 122

Sauer-Danfoss-Daikin LTD.  
Shin-Osaka TERASAKI 3rd Bldg. 6F  
1-5-28 Nishimiyahara, Yodogawa-ku  
Osaka 532-0004, Japan  
Phone: +81 6 6395 6066  
Fax: +81 6 6395 8585

[www.sauer-danfoss.com](http://www.sauer-danfoss.com)